

ADSP-21535 EZ-KIT LITE™

Evaluation System Manual

Second Edition, May 2002

Part Number
82-000603-01

Analog Devices, Inc.
Digital Signal Processing Division
One Technology Way
Norwood, MA 02062-9106



Limited Warranty

The EZ-KIT Lite evaluation system is warranted against defects in materials and workmanship for a period of one year from the date of purchase from Analog Devices or from an authorized dealer.

Disclaimer

Analog Devices, Inc. reserves the right to change this product without prior notice. Information furnished by Analog Devices is believed to be accurate and reliable. However, no responsibility is assumed by Analog Devices for its use; nor for any infringement of patents or other rights of third parties, which may result from its use. No license is granted by implication or otherwise under the patent rights of Analog Devices, Inc.

Trademark and Service Mark Notice

EZ-KIT Lite, VisualDSP++, VisualDSP++ logo, CROSSCORE, CROSSCORE logo, Blackfin and the Blackfin logo are trademarks of Analog Devices Inc. SoundMAX, EZ-ICE, SHARC, the SHARC logo, TigerSHARC, and the TigerSHARC logo, are registered trademarks of Analog Devices, Inc. All trademarks and logos are property of their respective holders.

Microsoft and Windows are registered trademarks of Microsoft Corporation.

Adobe and Acrobat are trademarks of Adobe Systems Incorporated.

PSDsoft Express and FlashLINK are trademarks of ST Microelectronics

All other brand and product names are trademarks or service marks of their respective owners.

Regulatory Compliance

The ADSP-21535 EZ-KIT Lite evaluation system has been certified to comply with the essential requirements of the European EMC directive 89/336/EEC (inclusive 93/68/EEC) and therefore carries the “CE” mark.

The ADSP-21535 EZ-KIT Lite evaluation system had been appended to the Technical Construction File referenced ‘**DSPTOOLS1**’ dated December 21, 1997 and was awarded CE Certification by an appointed European Competent Body as listed below.

Technical Certificate No: Z600ANA1.007

Issued by: Technology International (Europe) Limited
41 Shrivenham Hundred Business Park
Shrivenham, Swindon, SN6 8TZ, UK



The EZ-KIT Lite evaluation system contains ESD (electrostatic discharge) sensitive devices. Electrostatic charges readily accumulate on the human body and equipment and can discharge without detection. Permanent damage may occur on devices subjected to high-energy discharges. Proper ESD precautions are recommended to avoid performance degradation or loss of functionality. Store unused EZ-KIT Lite boards in the protective shipping package.



TABLE OF CONTENTS

LIST OF TABLES	vi
LIST OF FIGURES	vi
1 INTRODUCTION.....	1-1
1.1 For More Information About Analog Devices Products.....	1-2
1.2 For Technical or Customer Support.....	1-3
1.3 Purpose of This Manual	1-3
1.4 Intended Audience.....	1-3
1.5 Manual Contents	1-4
1.6 Online Help	1-4
2 GETTING STARTED.....	2-1
2.1 Overview	2-1
2.2 Contents of your EZ-KIT Lite Package	2-1
2.3 PC Configuration.....	2-2
2.4 Installation Tasks.....	2-2
2.4.1 Installing the VisualDSP++ Software	2-3
2.4.2 Installing the VisualDSP++ License	2-3
2.4.3 Installing the EZ-KIT Lite Debug Software.....	2-3
2.4.4 Setting Up the EZ-KIT Lite Hardware.....	2-4
2.4.5 Installing the EZ-KIT Lite USB Driver.....	2-5
2.4.6 Verifying Driver Installation	2-14
2.4.7 Starting VisualDSP++	2-15
3 USING THE EZ-KIT LITE	3-1
3.1 Overview	3-1
3.2 EZ-KIT Lite License Restrictions	3-2
3.3 Memory Map.....	3-2
3.4 Using the SDRAM Interface	3-3
3.5 Using Flash Memory.....	3-3
3.6 Using the Programmable Flag Pins.....	3-5
3.6.1 Using the Power Management Features	3-6
3.7 Example Programs	3-6
3.8 Using the Flash Programmer Utility	3-6
4 EZ-KIT LITE HARDWARE REFERENCE	4-1
4.1 Overview	4-1
4.2 System Architecture.....	4-2
4.2.1 External Bus Interface	4-3
4.2.2 SPORT0 – Audio Interface.....	4-3
4.2.3 Expansion Interface	4-4
4.2.4 JTAG Emulation Port	4-4
4.3 Jumper and DIP Switch Settings.....	4-5
4.3.1 Audio Input Select Jumper (JP1).....	4-5
4.3.2 Audio Codec Disable Jumper (JP2).....	4-6
4.3.3 Boot Mode Select Switch (SW1).....	4-6
4.3.4 DSP PLL Setup Switch (SW2).....	4-6
4.4 LEDs and Push Buttons.....	4-8

4.4.1	Programmable Flag LEDs (LED1, LED2, LED3, LED4)	4-9
4.4.2	USB Monitor LED (LED5)	4-9
4.4.3	Power LED (LED6)	4-9
4.4.4	Reset LEDs (LED7, LED8)	4-9
4.4.5	Non-Maskable Interrupt Push Button (SW3)	4-9
4.4.6	Programmable Flag Push Buttons (SW4, SW5, SW6, SW7)	4-10
4.4.7	Reset Push Button (SW8)	4-10
4.5	Connectors	4-11
4.5.1	Expansion Interface (P1, P2, P3)	4-12
4.5.2	FlashLINK (P4)	4-12
4.5.3	Audio (P5, P6)	4-12
4.5.4	USB (P7)	4-13
4.5.5	JTAG (P8)	4-13
4.5.6	SPORT0 (P9)	4-14
4.5.7	Power Connector (P10)	4-14
4.6	Specifications	4-14
4.6.1	Power Supply	4-15
4.6.2	Board Current Measurements	4-15
4.6.3	Mechanical Dimensions	4-1
APPENDIX A: BILL OF MATERIALS		A
APPENDIX B: SCHEMATIC		E
INDEX		1

LIST OF TABLES

Table 1-1: Related DSP Documents	1-5
Table 1-2: Related VisualDSP++ Documents	1-5
Table 2-1: Minimum PC Configuration.....	2-2
Table 3-1: EZ-KIT Lite Evaluation Board Memory Map	3-2
Table 3-2: SDRAM Default Settings.....	3-3
Table 3-3: Programmable Flag Pin Summary	3-5
Table 3-4: Power Management PF Settings.....	3-6
Table 4-1: Connector Interfaces.....	4-4
Table 4-2: Boot Mode Select Switch (SW1) Settings	4-6
Table 4-3: PLL Setup Switch (SW2) Functions	4-7
Table 4-4: Programmable Flag LEDs.....	4-9
Table 4-5: Programmable Flag Switches.....	4-10
Table 4-6: Power Connector	4-15
Table 4-7: Current Measurement Resistors	4-15

LIST OF FIGURES

Figure 2-1: EZ-KIT Lite Hardware Setup	2-4
Figure 2-2: Add New Hardware Wizard Dialog Box	2-5
Figure 2-3: Search for the driver.....	2-6
Figure 2-4: Search the CD-ROM.....	2-6
Figure 2-5: The driver is located.....	2-7
Figure 2-6: Search for .sys File Dialog Box	2-7
Figure 2-7: Open the .sys File.....	2-8
Figure 2-8: Copying Files	2-8
Figure 2-9: Finish the Software Installation	2-9
Figure 2-10: Found New Hardware Wizard	2-10
Figure 2-11: Search for a Suitable Driver.....	2-11
Figure 2-12: Locate Driver Files.....	2-12
Figure 2-13: Driver File Search Results	2-13
Figure 2-14: Completing Driver Installation Dialog Box.....	2-14
Figure 2-15: New Session Dialog Box	2-15
Figure 3-1: Flash Memory Map.....	3-4
Figure 4-1: System Architecture.....	4-2
Figure 4-2: Jumper Locations	4-5
Figure 4-3: Audio Input Jumper Settings (JP1).....	4-6
Figure 4-4: Default PLL Setup Switch Settings (SW2).....	4-7
Figure 4-5: LED and Push Button Locations.....	4-8
Figure 4-6: Connector Locations	4-11
Figure 4-7: Mechanical Drawing.....	4-1

1 INTRODUCTION

Thank you for purchasing the ADSP-21535 EZ-KIT Lite™ evaluation system. The evaluation board is designed to be used in conjunction with the VisualDSP++™ development environment to test the capabilities of the ADSP-21535 digital signal processor (DSP). The VisualDSP++ development environment gives you the ability to perform advanced application code development and debug such as:

- Create, compile, assemble, and link application programs written in C++, C and ADSP-2153x assembly
- Load, run, step, halt, and set breakpoints in application programs
- Read and write data and program memory
- Read and write core and peripheral registers
- Plot memory

Access to the ADSP-21535 from a PC is achieved through a USB port or an optional JTAG emulator. The USB interface gives unrestricted access to the ADSP-21535 DSP and the evaluation board peripherals. Analog Devices JTAG emulators offer faster communication between the host PC and target hardware. Analog Devices carries a wide range of in-circuit emulation products. To learn more about Analog Devices emulators and DSP development tools, go to <http://www.analog.com/dsp/tools/>.

ADSP-21535 EZ-KIT Lite provides example programs to demonstrate the capabilities of the evaluation board.

NOTE: The VisualDSP++ license provided with this EZ-KIT Lite evaluation system limits the use of internal memory to 176KB.

The board's features include:

- **Analog Devices ADSP-21535 DSP**
 - 300 MHz Core Clock Speed – default
 - Core Clock Speed – switch configurable
 - Boot Mode – switch configurable
- **USB Debugging Interface**
 - **NOTE:** this is not the DSP's USB interface

- **Analog Devices AD1885 48 kHz AC'97 SoundMAX® Codec**
 - Jumper-Selectable Line-In or Mic-In 3.5 mm Stereo Jack
 - Line-Out 3.5 mm Stereo Jack
- **SDRAM**
 - 4 M x 32-bit
- **Flash Memory**
 - 272 K x 16
- **Interface Connectors**
 - 14-Pin Emulator Connector for JTAG Interface
 - SPORT0 Connector
 - FlashLINK™ Connector (for flash programming)
 - Expansion Interface Connectors (not populated)
- **General-Purpose I/O**
 - 4 Push Buttons connected to DSP Programmable Flags
 - 1 Push Button connected to DSP Non-maskable Interrupt
 - 4 LEDs connected to DSP Programmable Flags
- **Real Time Clock**
- **Analog Devices ADP3331, ADP3338, ADP3339 & ADP3088 Voltage Regulators**

The EZ-KIT Lite board has a flash memory device that can be used to store user specific boot code. By configuring the boot mode switch (SW1) and by programming the flash, the board can run as a stand-alone unit. For information about using the flash, see section 3.5.

SPORT0 is interfaced with an audio Codec, allowing you to create audio signal processing applications. SPORT0 is also attached to an off-board connector to allow communication with other serial devices. For information about SPORT0, see section 4.2.2.

Additionally, the EZ-KIT Lite board provides access to most of the DSP's peripheral ports. Access is provided in the form of uninstalled expansion interface connectors. These DSP's USB pins are brought to this connector, but require additional circuitry to function as a USB port. The PCI bus of the DSP is not available at any connector of the EZ-Kit Lite. For information about the expansion interface, see section 4.2.3.

1.1 For More Information About Analog Devices Products

Analog Devices can be accessed on the Internet at <http://www.analog.com>. You can directly access the DSP Web pages at <http://www.analog.com/dsp>. This page provides access to DSP-specific technical information and documentation, product overviews, and product announcements. For specific information about DSP tools, go to <http://www.analog.com/dsp/tools>.

You may also obtain additional information about Analog Devices and its products in any of the following ways:

- FAX questions or requests for information to (781) 461-3010.
- Access the Computer Products Division File Transfer Protocol (FTP) site at 137.71.23.21 or <ftp://ftp.analog.com>.

1.2 For Technical or Customer Support

You can reach our Customer Support group in the following ways:

- Contact your local Analog Devices sales office or an authorized Analog Devices distributor.
- Call:
(800)-ANALOGD
- E-mail general DSP questions to:
dsp.support@analog.com
dsp.europe@analog.com (European customer support)
- E-mail DSP Tools questions to:
dsptools.support@analog.com
- Submit a DSP Tools Technical Support Form:
http://forms.analog.com/Form_Pages/DSP/tools/contactDSP.asp

1.3 Purpose of This Manual

The *ADSP-21535 EZ-KIT Lite Evaluation System Manual* provides instructions for using the hardware and installing the software on your PC. This manual provides guidelines for running your own code on the ADSP-21535 EZ-KIT Lite. This manual also provides a description of the use and configuration of the components on the evaluation board. Finally, a schematic and a bill of materials are provided as reference for future ADSP-21535 board designs.

1.4 Intended Audience

This manual is a user's guide and reference to the ADSP-21535 EZ-KIT Lite evaluation system. DSP programmers who are familiar with the Analog Devices Blackfin™ DSP architecture, operation, and programming are the primary audience for this manual.

DSP programmers who are unfamiliar with Analog Devices Blackfin DSPs can use this manual in conjunction with the *ADSP-21535 DSP Hardware Reference* and the *ADSP-21535 DSP Instruction Set*, which describe the DSP architecture and instruction set. DSP programmers who are unfamiliar with VisualDSP++ should refer to the VisualDSP++ Help menu and the *VisualDSP++ User's Guide*. For the locations of these documents, refer to section 1.6.

1.5 Manual Contents

This manual contains the following information:

- Chapter 1 — Introduction
Provides manual information and Analog Devices contact information.
- Chapter 2 — Getting Started
Provides software and hardware installation procedures, PC system requirements, and basic board information.
- Chapter 3 — Using the EZ-KIT Lite
Provides information on the EZ-KIT Lite from a programmers perspective, and provides an easy-to-access memory map.
- Chapter 4 — EZ-KIT Lite Hardware Reference
Provides information on the hardware aspects of the evaluation system.
- Appendix A — Bill of Materials
Provides a list of components used to manufacture the EZ-KIT Lite board.
- Appendix B — Schematics
Provides the resources to allow EZ-KIT Lite board-level debugging or to use as a reference design.

1.6 Online Help

Your software installation kit includes online Help as part of the Windows® interface. These help files provide information about VisualDSP++ and the ADSP-21535 EZ-KIT Lite evaluation system.

To view VisualDSP++ Help, click on the *Help* menu item or go to the Windows task bar and select Start\Programs\VisualDSP\VisualDSP++ Help.

To view help on additional ADSP-21535 EZ-KIT Lite features, go to the windows task bar and select Start\Programs\VisualDSP\EZ-KIT Help.

The documents in the following tables can be found through online Help or in the Docs folder of your VisualDSP++ installation.

For more documentation, please go to <http://www.analog.com/technology/dsp/library.html>.

Table 1-1: Related DSP Documents

Document Name	Description
<i>ADSP-21535 DSP Datasheet</i>	General functional description, pinout, and timing.
<i>ADSP-21535 SHARC DSP Hardware Reference</i>	Description of internal DSP architecture and all register functions.
<i>Blackfin DSP Instruction Set Reference</i>	Description of all allowed DSP assembly instructions.

Table 1-2: Related VisualDSP++ Documents

Document Name	Description
<i>VisualDSP++ 2.0 Users Guide for BLACKfin DSPs</i>	Detailed description of <i>VisualDSP++ 2.0</i> features and usage.
<i>VisualDSP++ 2.0 Assembler & Preprocessor Manual for BLACKfin DSPs</i>	Description of the assembler function and commands for Blackfin family DSPs
<i>VisualDSP++ 2.0 C/C++ Compiler and Library Manual for BLACKfin DSPs</i>	Description of the compiler function and commands for Blackfin family DSPs
<i>VisualDSP++ 2.0 Linker & Utilities Manual for BLACKfin DSPs</i>	Description of the linker function and commands for the Blackfin family DSPs

- **Important:** If you plan to use the EZ-KIT Lite board in conjunction with a JTAG emulator, refer to the documentation that accompanies the emulator.

2 GETTING STARTED

2.1 Overview

This chapter provides the information you need to begin using ADSP-21535 EZ-KIT Lite evaluation system. For correct operation install the software and hardware in the order presented in section 2.4. This chapter has the following sections:

- [Contents of your EZ-KIT Lite Package](#) (Section 2.2)
Provides a list of the components that are shipped with this EZ-KIT Lite evaluation system.
- [PC Configuration](#) (Section 2.3)
Describes the minimum requirements for the PC to work with the EZ-KIT Lite evaluation system.
- [Installation Tasks](#) (Section 2.4)
Describes the step-by-step procedure for setting up the hardware and software.

2.2 Contents of your EZ-KIT Lite Package

Your ADSP-21535 EZ-KIT Lite evaluation system package contains the following items.

- *EZ-KIT Lite Quick Start Guide*
- ADSP-21535 EZ-KIT Lite board
- VisualDSP++ CD with license.
- ADSP-21535 EZ-KIT Lite CD, containing:
 - EZ-KIT Lite specific debug software
 - USB driver files
 - Example programs
 - ADSP-21535 EZ-KIT Lite manual (this document)
 - Flash Programmer Utility
- Installation Quick Reference Card for VisualDSP++
- Universal 7.5V DC power supply
- 5 meter USB type A to type B cable
- Registration card - please fill out and return

If any item is missing, contact the vendor where you purchased your EZ-KIT Lite or contact Analog Devices, Inc.

The EZ-KIT Lite evaluation system contains ESD (electrostatic discharge) sensitive devices. Electrostatic charges readily accumulate on the human body and equipment and can discharge without detection. Permanent damage may occur on devices subjected to high-energy discharges. Proper ESD precautions are recommended to avoid performance degradation or loss of functionality. Store unused EZ-KIT Lite boards in the protective shipping package.



2.3 PC Configuration

For correct operation of the VisualDSP++ software and the EZ-KIT Lite, your computer must have the minimum configuration shown in Table 2-1.

Table 2-1: Minimum PC Configuration

Windows® 98, Windows® 2000
Intel (or comparable) 166MHz processor
VGA Monitor and color video card
2-button mouse
50 MB free on hard drive
32 MB RAM
Full-speed USB port
CD-ROM Drive

- **NOTE: This EZ-KIT Lite does not run under Windows 95 or Windows NT.**

2.4 Installation Tasks

The following tasks are provided for the safe and effective use of the ADSP-21535 EZ-KIT Lite. Follow these instructions in the order presented to ensure correct operation of your software and hardware.

1. VisualDSP++ software installation
2. VisualDSP++ license installation
3. EZ-KIT Lite debug software installation
4. EZ-KIT Lite hardware setup
5. EZ-KIT Lite USB driver installation
6. USB driver installation verification
7. VisualDSP++ startup

2.4.1 Installing the VisualDSP++ Software

This EZ-KIT Lite comes with the latest version of VisualDSP++ for the Blackfin DSP family. You must install this software before installing the EZ-KIT Lite debug software.

Insert the VisualDSP++ CD-ROM into the CD-ROM drive. If Auto Run is enabled on your PC, the home screen of the VisualDSP++ install wizard will automatically appear. If not, choose **Run** from the **Start** menu, and enter **D:\Setup.exe** in the **Open** field, where D is the name of your local CD-ROM drive. Click on the **Install VisualDSP++** option. This will launch the setup wizard. Follow the on-screen instructions.

2.4.2 Installing the VisualDSP++ License

Before the VisualDSP++ software can be used, the license must be installed.

To install the VisualDSP++ license:

1. Ensure that VisualDSP++ has been installed first.
 2. Insert the VisualDSP++ CD-ROM into the CD-ROM drive if it is not already in the drive.
 3. Once the CD-ROM browser appears, select the **Install License** option.
 4. Follow the setup wizard instructions.
- **NOTE: You will need the serial number located on the back of the CD-ROM sleeve.**

2.4.3 Installing the EZ-KIT Lite Debug Software

VisualDSP++ communicates with the EZ-KIT Lite board using the EZ-KIT Lite debug software. This software is supplied on the EZ-KIT Lite CD-ROM.

To install the EZ-KIT Lite debug software:

1. Ensure that VisualDSP++ has been installed first.
2. Close all Windows applications. The install will not work correctly if any VisualDSP++ applications are running.
3. Insert the EZ-KIT Lite CD-ROM into the CD-ROM drive. If Autorun is enabled on your PC, the home screen of the EZ-KIT Lite install wizard will automatically appear. If not, choose **Run** from the **Start** menu, and enter **D:\Setup.exe** in the **Open** field, where D is the name of you local CD-ROM drive. Click the **Install EZ-KIT Lite Software** option. This will launch the setup wizard. Follow this wizard with the on-screen instructions.

2.4.4 Setting Up the EZ-KIT Lite Hardware

The EZ-KIT Lite evaluation system contains ESD (electrostatic discharge) sensitive devices. Electrostatic charges readily accumulate on the human body and equipment and can discharge without detection. Permanent damage may occur on devices subjected to high-energy discharges. Proper ESD precautions are recommended to avoid performance degradation or loss of functionality. Store unused EZ-KIT Lite boards in the protective shipping package.



The ADSP-21535 EZ-KIT Lite board is designed to run outside your personal computer as a stand-alone unit. You do not have to open your computer case.

To connect the EZ-KIT Lite board:

1. Remove the EZ-KIT Lite board from the package. Be careful when handling the board to avoid the discharge of static electricity, which may damage some components.
2. [Figure 2-1](#) shows the default jumper settings, DIP Switch, connector locations, and LEDs used in installation. Confirm that your board is set up in the default configuration before continuing.

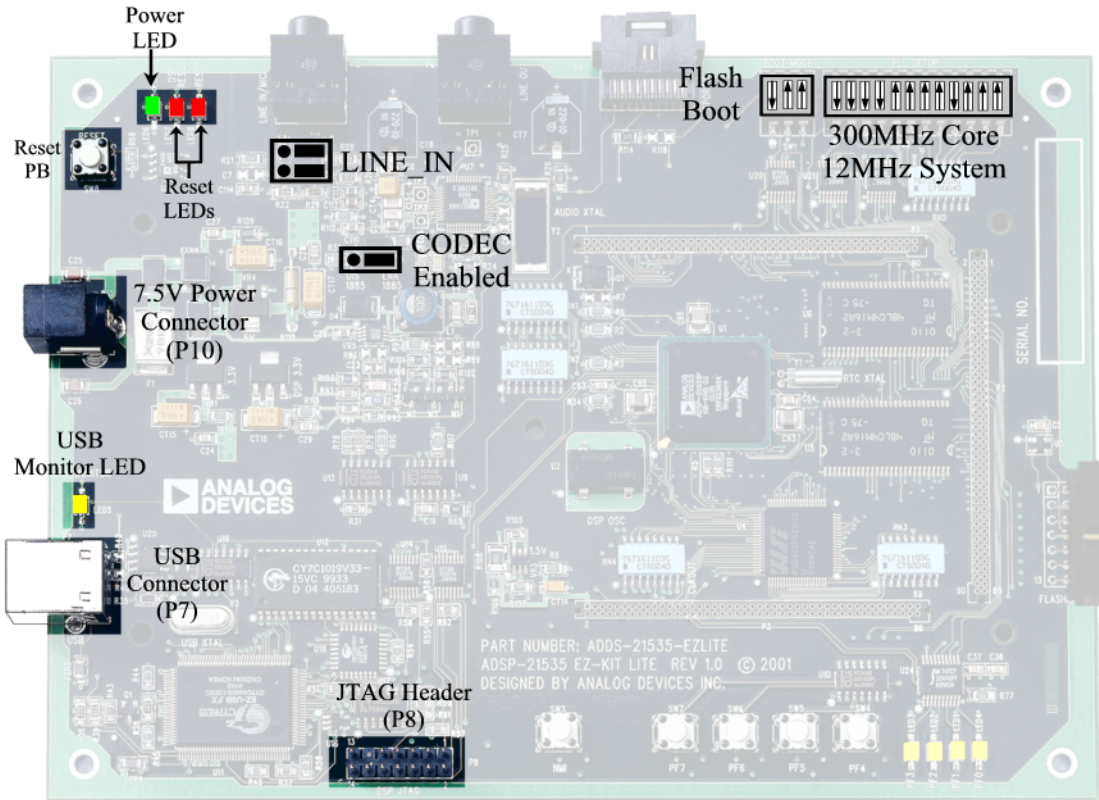

Figure 2-1: EZ-KIT Lite Hardware Setup

3. Plug the provided power supply into P10 on the EZ-KIT Lite board. Visually verify that the green power LED (LED6) is on. Also verify that the two red reset LEDs (LED7 and LED8) go on for a moment and then go off.
4. Connect the USB cable to an available full speed USB Port and to P7 on the ADSP-21535 EZ-KIT Lite board.

2.4.5 Installing the EZ-KIT Lite USB Driver

The EZ-KIT Lite evaluation system can be installed on Windows 98 and Windows 2000 and requires one full-speed USB port. Section 2.4.5.1 describes the installation on Windows 98. Section 2.4.5.2 describes the installation on Windows 2000.

2.4.5.1 Windows 98 USB Driver Installation

Before using the ADSP-21535 EZ-KIT Lite for the first time, the Windows 98 USB driver must first be installed.

To install the USB driver:

1. Insert the EZ-KIT Lite CD-ROM into the CD-ROM drive.

The connection of the device to the USB port will activate the Windows 98 “Add New Hardware Wizard” as shown in Figure 2-2.



Figure 2-2: Add New Hardware Wizard Dialog Box

2. Click **Next**.
3. Select **Search for the best driver for your device** as shown in [Figure 2-3](#).

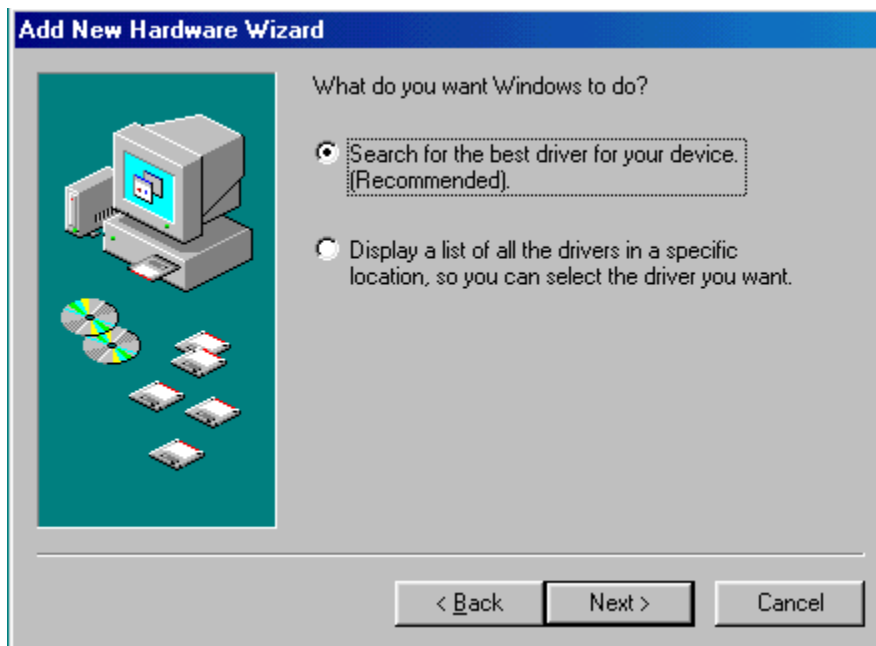

Figure 2-3: Search for the driver

4. Click **Next**.
5. Select **CD-ROM drive** as shown in [Figure 2-4](#).



Figure 2-4: Search the CD-ROM

6. Click **Next**.

Windows 98 will locate the WmUSBEz.inf file that is on the CD-ROM as shown in [Figure 2-5](#).



Figure 2-5: The driver is located

7. Click **Next**.

The **Coping Files** dialog box appears ([Figure 2-6](#)).

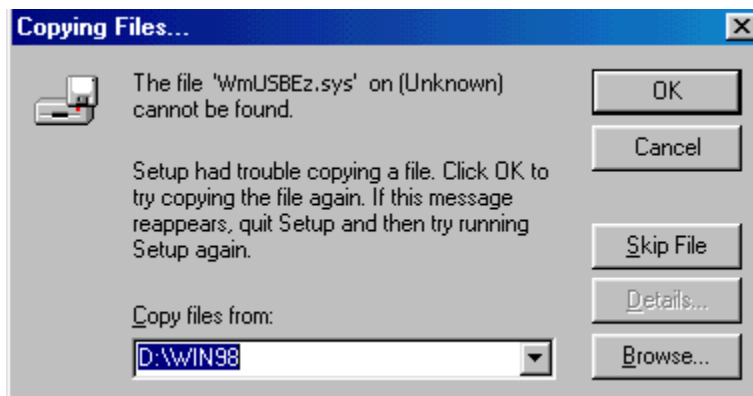

Figure 2-6: Search for .sys File Dialog Box

8. Click **Browse**.

Figure 2-7 will appear.

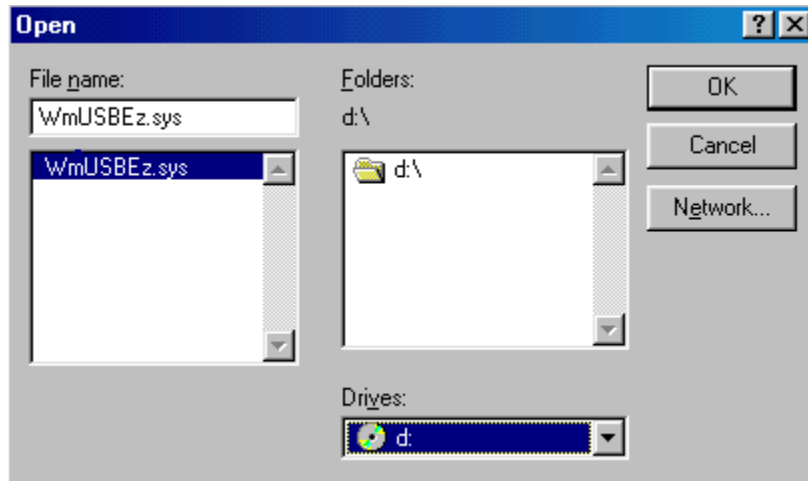

Figure 2-7: Open the .sys File

9. In **Drives** select your CD-ROM drive.
10. Click **OK**.

Figure 2-8 will appear.

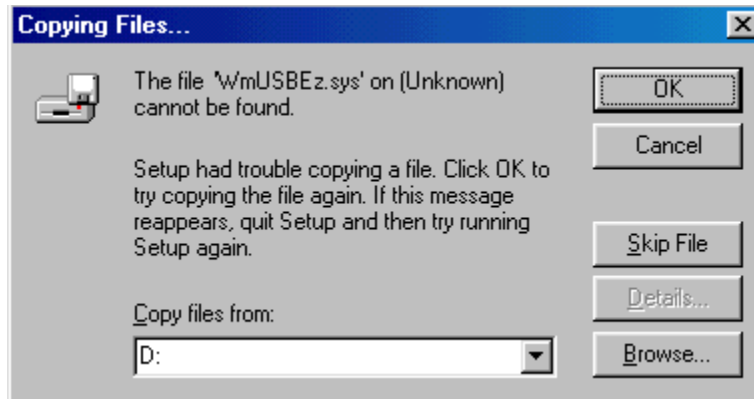

Figure 2-8: Copying Files

11. Click **OK**.

The driver installation is now complete as shown in [Figure 2-9](#).

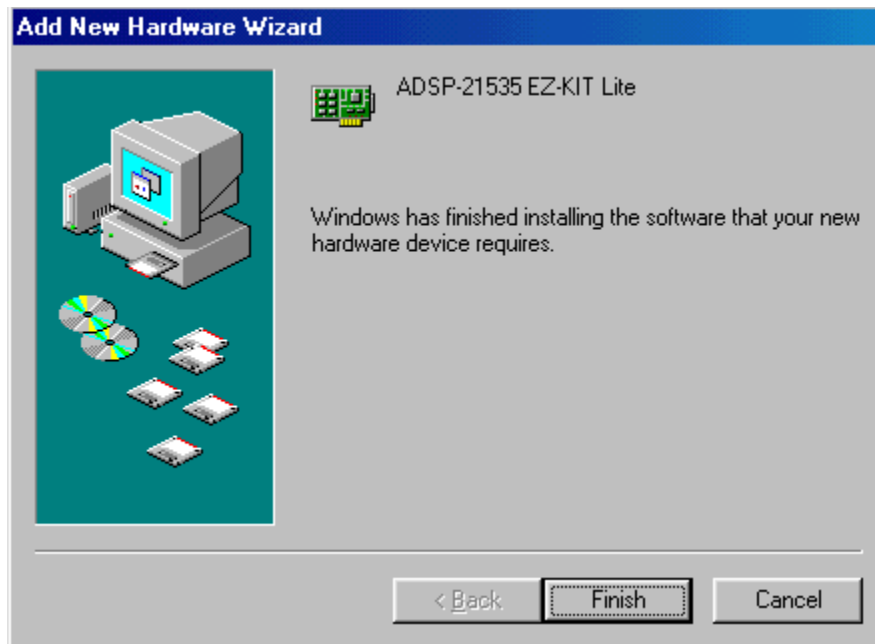

Figure 2-9: Finish the Software Installation

12. Click **Finish** to exit the wizard.

Verify the installation by following the instructions in section [2.4.6](#).

2.4.5.2 Windows 2000 USB Driver Installation

Before using the ADSP-21535 EZ-KIT Lite for the first time, the Windows 2000 USB driver must first be installed.

To install the USB Driver:

1. Insert the EZ-KIT Lite CD-ROM into the CD-ROM drive.

The connection of the device to the USB port will activate the Windows 2000 “Found New Hardware Wizard” as shown in [Figure 2-10](#).



Figure 2-10: Found New Hardware Wizard

2. Click **Next**.

3. Select **Search for a suitable driver for my device** as shown in [Figure 2-11](#).



Figure 2-11: Search for a Suitable Driver

4. Click **Next**.

5. Ensure that **CD-ROM drives** is selected as shown in [Figure 2-12](#).



Figure 2-12: Locate Driver Files

6. Click **Next**.

Figure 2-13 appears.

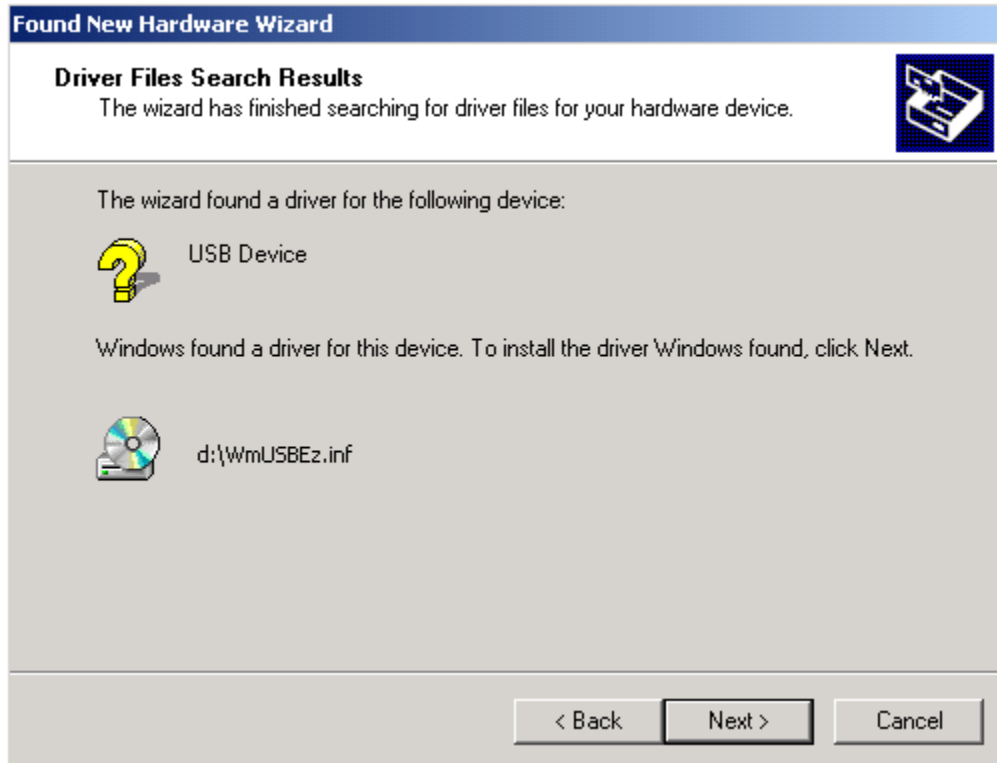

Figure 2-13: Driver File Search Results

7. Click **Next**.

Windows 2000 will automatically install the ADSP-21535 EZ-KIT Lite driver. The driver installation is now complete as shown in [Figure 2-14](#).

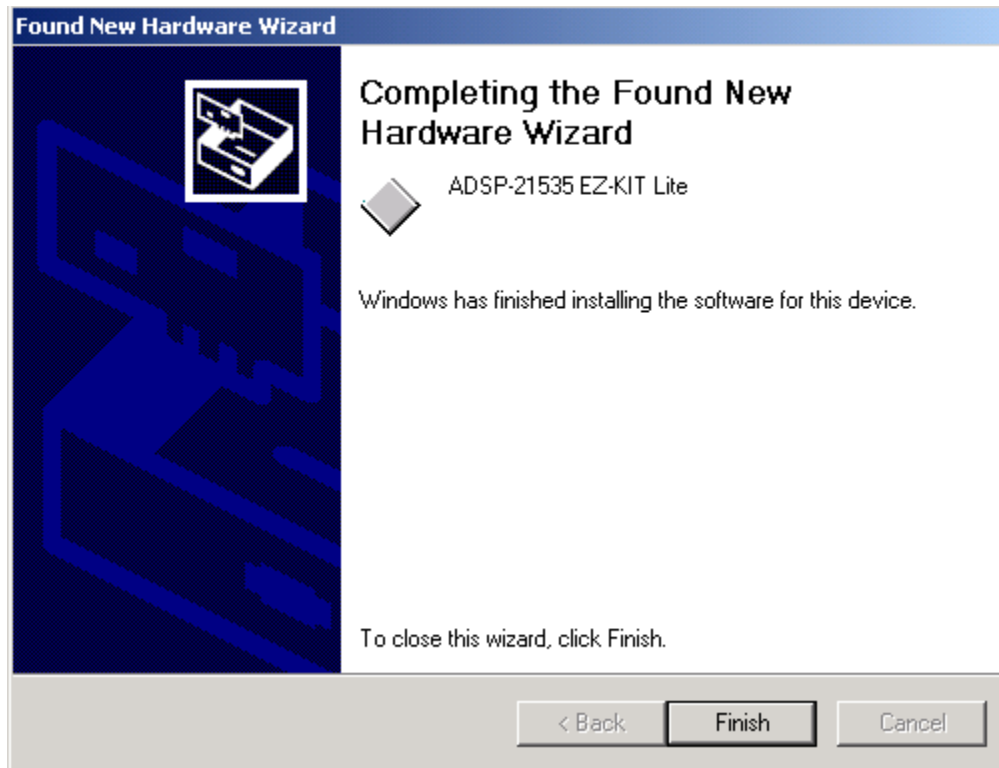

Figure 2-14: Completing Driver Installation Dialog Box

8. Click **Finish** to exit the wizard.

Verify the installation by following the instructions in section [2.4.6](#).

2.4.6 Verifying Driver Installation

Before you use the EZ-KIT Lite evaluation system, verify that the USB driver software is installed properly:

1. Ensure that the USB cable is connected to the evaluation board and the PC.
2. Verify that the yellow USB monitor LED (LED5) is lit. This signifies that the board is communicating properly with the host PC and is ready to run VisualDSP++.

2.4.7 Starting VisualDSP++

To start debugging, set up a session in VisualDSP++.

1. Verify that the yellow USB monitor LED (LED5, located near the USB connector) is lit. This signifies that the board is communicating properly with the host PC, and is ready to run VisualDSP++.
2. Hold down the **Control** (CTRL) key.
3. Select the **Start** button on the Windows taskbar, and then choose **Programs\VisualDSP\VisualDSP++**.

The *Session List* dialog box appears if you already have existing sessions. Skip to step 4 if this is the first time running VisualDSP++.

4. Click on **New Session**.
5. The **New Selection** dialog will appear as shown in [Figure 2-15](#).

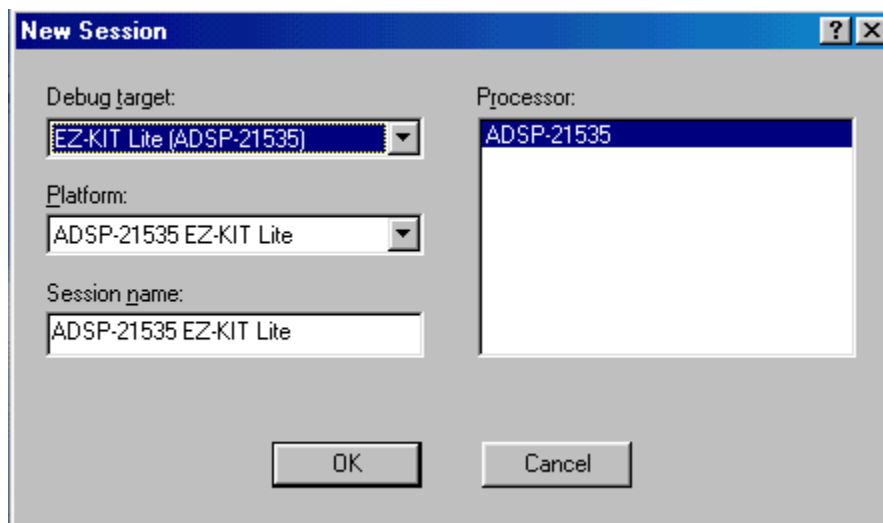

Figure 2-15: New Session Dialog Box

6. In **Debug Target**, choose **EZ-KIT Lite (ADSP-21535)**.
7. Type a new target name in **Session Name** or accept the default name.
8. Click **OK** to return to the **Session List**. Highlight the new session and click **Activate**.

3 USING THE EZ-KIT LITE

3.1 Overview

This chapter provides specific information to assist you with developing programs for the ADSP-21535 EZ-KIT Lite board. This information appears in the following sections:

- [EZ-KIT Lite License Restrictions](#) (Section 3.2)
Describes the restrictions of the VisualDSP++ license shipped with the EZ-KIT Lite.
- [Memory Map](#) (Section 3.3)
Defines the memory map to assist in developing programs for the EZ-KIT Lite evaluation system.
- [Using the SDRAM Interface](#) (Section 3.4)
Defines the register values to configure the on-board SDRAM.
- [Using Flash Memory](#) (Section 3.5)
Describes how to program and use the on-board flash memory.
- [Using the Programmable Flag Pins](#) (Section 3.6)
Describes the function and use of the programmable flag pins on the EZ-KIT Lite evaluation system.
- [Example Programs](#) (Section 3.7)
Provides information about the example programs included in the ADSP-21535 EZ-KIT Lite evaluation system.
- [Using the Flash Programmer Utility](#) (Section 3.8)
Provides information on the Flash Programmer Utility included with the EZ-KIT Lite software.

For more detailed information about programming the ADSP-21535, see the documents referred to in section 1.6.

3.2 EZ-KIT Lite License Restrictions

The license shipped with the EZ-KIT Lite imposes the following restrictions:

- Internal Memory space is limited to 176 KB of the ADSP-21535 internal memory space
- No connections to Simulator or Emulator sessions are allowed.
- Only one EZ-KIT Lite can be connected to the host PC and debugged at a time

3.3 Memory Map

The ADSP-21535 has internal SRAM that can be used for instruction storage or data storage. The configuration of internal SRAM is detailed in the *ADSP-21535 DSP Hardware Reference*.

The ADSP-21535 EZ-KIT Lite board contains 272K x 16 bits of external flash memory. This memory is connected to the DSP's ~AMS0 memory select pin. The external memory interface is also connected to 4M x 32-bit SDRAM memory. This memory is connected to the ~SMS0 pin.

Table 3-1: EZ-KIT Lite Evaluation Board Memory Map

	Start Address	End Address	Content
External Memory	0x0000 0000	0x00FF FFFF	SDRAM Bank 0 (SDRAM) See section 3.4
	0x2000 0000	0x2009 FFFF	ASYNC Memory Bank 0 (FLASH) See section 3.5
	All other locations		Not used
Internal Memory	0xF000 0000	0xF003 FFFF	L2 SRAM 256 KB
	0xFF80 0000	0xFF80 3FFF	Data Bank A 16 KB
	0xFF90 0000	0xFF90 3FFF	Data Bank B 16 KB
	0xFFA0 0000	0xFFA0 3FFF	Instruction SRAM 16 KB
	0xFFB0 0000	0xFFB0 0FFF	Scratch Pad SRAM 4 KB
	0xFFC0 0000	0xFFDF FFFF	System MMRs 2 MB
	0xFFE0 0000	0xFFFF FFFF	Core MMRs 2 MB
All other locations		Reserved	

3.4 Using the SDRAM Interface

In order to use the 4M x 32 bits (16 MB) of SDRAM memory, the three SDRAM control registers must be initialized. The following table shows the standard configuration for these registers when using the EZ-KIT Lite in the default configuration. These numbers were derived using the M48LC4M16ATG-75 with a system clock frequency of 120 MHz.

Table 3-2: SDRAM Default Settings

Register	Value	Function
EBIU_SDRRC	0x0000074A	RDIV = 1866 clock cycles
EBIU_SDBCTL	0x00000001	Bank 0 enabled Bank 0 size = 16 MB Bank 0 column address width = 8 bits
EBIU_SDGCTL	0x0091998F	32 bit data path External buffering timing disabled $t_{WR} = 2$ SCLK cycles $t_{RCD} = 3$ SCLK cycles $t_{RP} = 3$ SCLK cycles $t_{RAS} = 6$ SCLK cycles pre-fetch disabled CAS latency = 3 SCLK cycles SCLK1 disabled

If you are in an EZ-KIT Lite session (that is, not using an emulator), the SDRAM registers are configured automatically through the debugger. The debugger uses the values in [Table 3-2](#) whenever bank 0 is accessed through the debugger (such as viewing memory windows or loading a program). Clearing the appropriate checkbox on the Target Options dialog box, which is accessible through the Settings pull-down menu, disables this feature and allows manual configuration.

An example program is included in the EZ-KIT installation directory, which demonstrates how to setup the SDRAM interface.

3.5 Using Flash Memory

The DSM2150 Flash/PLD chip provides a total of 272K x 16 bits of external flash memory, arranged into two independent flash arrays (boot and main). The chip also has a series of configuration registers to control I/O and PLD. This chip is initially configured with the memory sectors mapped to the DSP as shown below in [Figure 3-1](#).

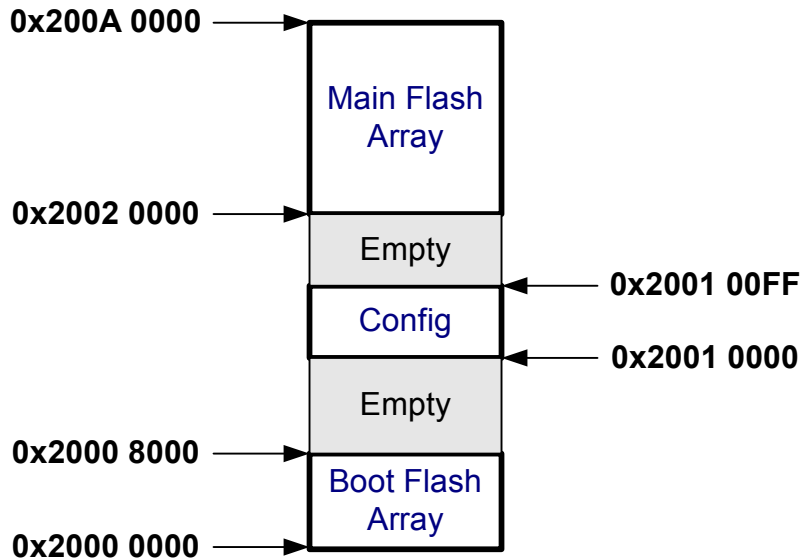

Figure 3-1: Flash Memory Map

Use PSDsoft Express™ to modify the default settings for the flash memory, the DSM project must be modified and the flash must be reprogrammed using FlashLINK™. The default project files can be found in, \...\VisualDSP\Blackfin\EZ-KITs\ADSP-21535\DSMConfigFiles. Analog Devices does not provide any support for setting up the DSM2150 with PSDsoft Express™ or programming it using FlashLINK™. Email STMicroelectronics for technical assistance at apps.psd@st.com.

To program the flash with your boot code, you must first create a loader file from your DSP code. You will need to set up the loader in VisualDSP++ depending on how you will be booting the flash. The two possibilities are to boot the DSP in 16-bit external execution mode or in 8-bit boot mode. See section 4.3.3 for the boot mode settings.

Next, the loader file must be programmed into the flash. This can be done through the DSP using the VisualDSP++ Flash Programmer Utility (see section 3.8) or using by using the FlashLink programmer.

The DSM2150 can be reprogrammed using the FlashLINK™ JTAG programming cable available from STMicroelectronics (www.st.com/psd) for approximately \$59. FlashLINK™ plugs into any PC parallel port. The software development tool, PSDsoft Express, is required to modify the configuration of the DSM2150 and operate the FlashLINK™ cable. PSDsoft Express™ can be downloaded at no charge from at www.st.com/psd.

3.6 Using the Programmable Flag Pins

The ADSP-21535 has 16 asynchronous Programmable Flag (PF) I/O pins. During reset PF0-PF9 function as inputs to the internal PLL of the DSP. They are not valid until 120uS after reset. [Table 3-3](#) describes how the PFs are used on the EZ-KIT Lite.

After a DSP reset, all of the PF pins are initialized as inputs. The direction of the PF is configured by the *FIO_DIR* Memory Mapped Register (MMR). The PFs are set high (1) using the *FIO_FLAG_S* and cleared (0) using the *FIO_FLAG_C* MMRs. For more information on configuring the PF pins, see the *ADSP-21535 DSP Hardware Reference Manual*.

All of the PFs can be brought out to the expansion connector P2. The location of the PF nets can be found in [APPENDIX B: SCHEMATIC](#).

Table 3-3: Programmable Flag Pin Summary

Flag	Connected to	Use
PF0	LED4	PF0-3 are connected to the LEDs. These can be used to light an LED when a routine completes.
PF1	LED1	
PF2	LED2	
PF3	LED3	
PF4	SW4	PF4-7 are connected to the push buttons on the EZ-KIT Lite board and are for user input. Your routine can monitor and execute specific code when a push button has been pressed.
PF5	SW5	
PF6	SW6	
PF7	SW7	
PF8		Not used
PF9		Not used
PF10		Not used
PF11		Not used
PF12	PMGMT0	These are used to change the internal voltage of the DSP. Refer to section 3.6.1 for more information.
PF13	PMGMT1	
PF14	PMGMT2	
PF15	U7.11	Connected to the reset of the AD1885 Codec (U7). This signal must be output as a high (1) to enable the AD1885 Codec.

3.6.1 Using the Power Management Features

PF14-PF12 allow you to program the core voltage of the DSP. The default core voltage is 1.5V. Table 3-4 gives the value of the core voltage corresponding to the state of these PFs.

When lowering the core voltage of the DSP, the frequency of the DSP must be taken into consideration. As you lower the core voltage of the DSP, the frequency the core is running at must be decrease.

Table 3-4: Power Management PF Settings

PF14	PF13	PF12	VDD INT
0	0	0	0.9V
0	0	1	1.0V
0	1	0	1.1V
0	1	1	1.2V
1	0	0	1.3V
1	0	1	1.4V
* 1	1	0	1.5V
1	1	1	1.6V

* Denotes Default

3.7 Example Programs

Example programs are provided with the ADSP-21535 EZ-KIT Lite to demonstrate various capabilities of the evaluation board. These programs are installed with the EZ-KIT Lite software and can be found in \\...\VisualDSP\Blackfin\EZ-KITs\ADSP-21535\Examples. Please refer to the readme files provided with each example program for more information.

3.8 Using the Flash Programmer Utility

The ADSP-21535 EZ-KIT Lite evaluation system includes a Flash Programmer Utility. The utility allows you to program the flash on the EZ-KIT Lite. This utility must be installed separately from the debug software. To install the utility, insert the EZ-KIT Lite CD-ROM and follow the steps in the installation wizard. After it has been installed, it is available from the Tools pull-down menu in VisualDSP++.

For more information on the Flash Programmer Utility go to the **Start** menu and choose **Programs\VisualDSP\Flash Programmer Help**.

4 EZ-KIT LITE HARDWARE REFERENCE

4.1 Overview

This chapter describes the hardware design of the ADSP-21535 EZ-KIT Lite board. The following topics are covered:

- [System Architecture](#) (Section 4.2)
Describes the configuration of the DSP as well as a description of how all of the components on the board interface with the DSP.
- [Jumper and DIP Switch Settings](#) (Section 4.3)
Shows the location and describes the function of all the configuration jumpers and DIP Switches.
- [LEDs and Push Buttons](#) (Section 4.4)
Shows the location and describes the function of all the LEDs and push buttons.
- [Connectors](#) (Section 4.5)
Shows the location and gives the part number for all of the connectors on the board. Also, the manufacturer and part number information is given for the mating part.
- [Specifications](#) (Section 4.6)
Gives the requirements for powering the board.

4.2 System Architecture

The EZ-KIT Lite has been designed to demonstrate the capabilities of the ADSP-21535 DSP. This section describes the DSP's configuration on the EZ-KIT Lite board.

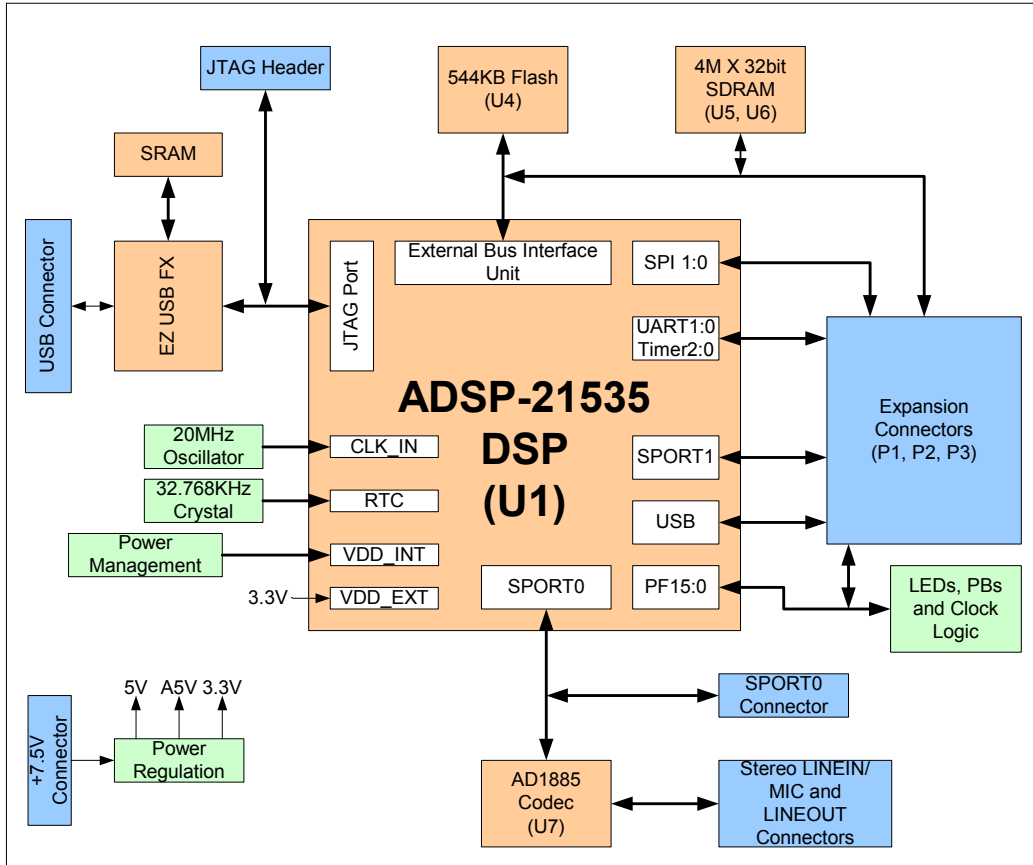

Figure 4-1: System Architecture

The DSP has a default core voltage of 1.5V. Refer to section 3.6.1 for more information about changing the core voltage while the DSP is running. The voltage of the DSP's peripheral interface is 3.3V.

A 20 MHz oscillator supplies the input clock to the DSP. The speed at which the core and peripherals operate is determined by the configuration of the multiplier select switch (SW2) at reset. (See section 4.3.4.) By default, the DSP core runs at 300 MHz and the peripheral interface runs at 120 MHz. A 32.768 kHz crystal supplies the Real Time Clock (RTC) inputs of the DSP.

The EZ-KIT Lite board can be configured to boot in all of the possible ADSP-21535 boot modes. For information about configuring the boot mode, see section 4.3.3.

4.2.1 External Bus Interface

The External Bus Interface Unit (EBIU) is connected to 4M x 32 bits of SDRAM (16 MB). This memory is connected to the synchronous memory select 0 (~SMS0) pin. Refer to section 3.4 for information about configuring the SDRAM.

The EBIU is also connected to 272K x 16 bits of flash memory. This memory is connected to the asynchronous memory select (~AMS0) pin. The DSP can use this memory both for booting and storing information during normal operation. Refer to section 3.5 for information about using the flash memory.

All of the address, data, and control signals are available externally via the extender connectors (P1-3). The pinout of these connectors can be found in [APPENDIX B: SCHEMATIC](#).

4.2.2 SPORT0 – Audio Interface

SPORT0) is connected to the AD1885 SoundMAX Codec (U7). Two 3.5mm stereo jacks (P5, P6) allow audio to be input and output. You can supply an audio input to the Codec microphone input channel (MIC1) or to the stereo LINE_IN input channel. The jumper settings of JP1 determine the Codec channel driven by the input jack (P5). For information about configuring JP1, see section 4.3.1.

SPORT0 is also routed to an off-board connector (P9). When using the off-board connector, the Codec must be held in reset, so that it does not drive any of the SPORT0 signals. The Codec can be held in reset by driving PF15 low or by setting up JP2 to always hold the Codec in reset (see section 4.3.2). PF15 must be pulled HI (1) for the Codec to function.

➤ **NOTE: TCLK0 and RCLK0 pins are shorted together using R114 and R118.**

4.2.3 Expansion Interface

The expansion interface consists of the footprints for 3 connectors. The following table shows the interfaces each connector provides. For the exact pin-out of these connectors refer to [APPENDIX B: SCHEMATIC](#). Analog Devices does not populate these connectors or provide any additional support for this interface. The mechanical locations of these connectors can be found in section [4.6.3](#).

Table 4-1: Connector Interfaces

Connector	Interfaces
P1	5V, GND, Address, Data
P2	3.3V, GND, EBUI control signals, PF0-15, SPI0-1, SPORT1, UART0-1, TMR0-2, NMI
P3	1.5V, GND, Reset, USB, CLKOUT, SLEEP

Limits to the current and to the interface speed must be taken into consideration if you use this interface. The maximum current limit is dependent on the regulator used and its capabilities. Additional circuitry can also add extra loading to signals, decreasing their maximum effective speed.

- **Analog Devices does not support and is not responsible for the effects of additional circuitry.**

4.2.4 JTAG Emulation Port

The JTAG emulation port allows an emulator to access the DSP's internal and external memory through a 6-pin interface. The JTAG emulation port of the DSP is also connected to the USB debugging interface (**NOTE:** This is not the DSP's USB interface). When an emulator is connected to the board at P8, the USB debugging interface is disabled. See section [4.5.5](#) for more information about the JTAG connector.

To learn more about available emulators, contact Analog Devices (see section [1.1](#)).

4.3 Jumper and DIP Switch Settings

This section describes the function of all the jumpers and DIP switches. The following figure shows the location of all the jumpers and DIP switches.

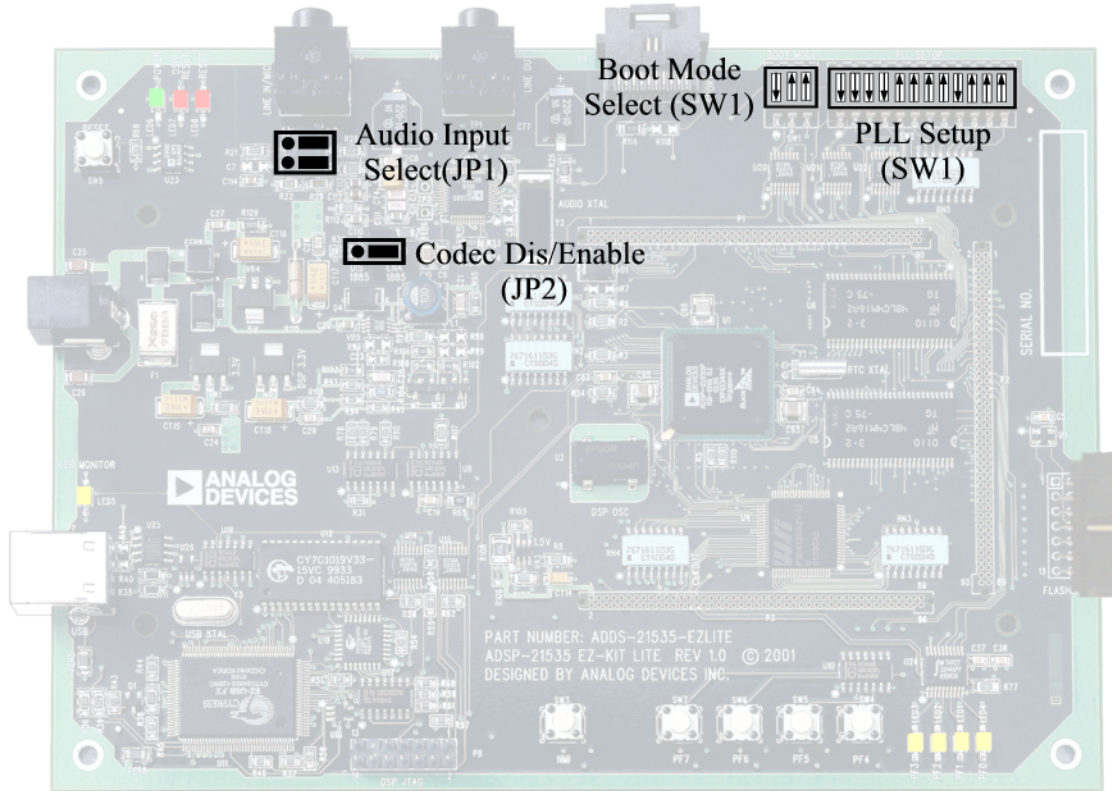

Figure 4-2: Jumper Locations

4.3.1 Audio Input Select Jumper (JP1)

The audio input jack (P5) can be connected to the MIC1 or the LINEIN input channels of the AD1885 Codec (U7). When the JP1 jumpers connect pins 1 and 3 and pins 2 and 4, P3 connects to the mono MIC1 channel. When the jumpers connect pins 3 and 5 and pins 4 and 6, P5 connects to the stereo LINE_IN channel of the AD1885 Codec. These jumper settings are illustrated below in [Figure 4-3](#). (The words MIC and LINE are on the board as a reference)

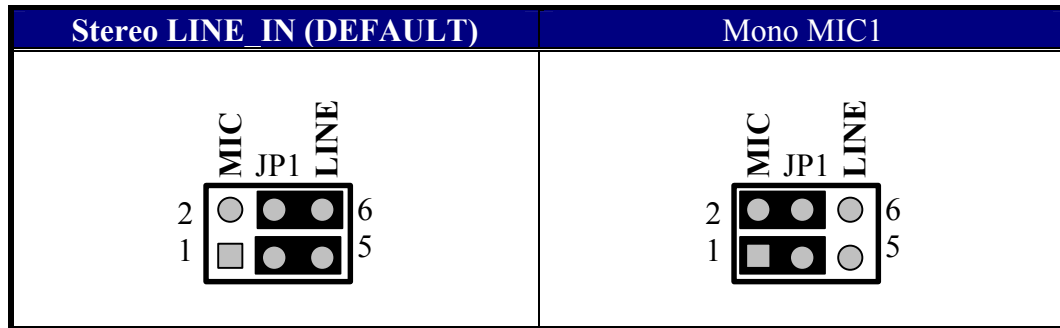

Figure 4-3: Audio Input Jumper Settings (JP1)

4.3.2 Audio Codec Disable Jumper (JP2)

Placing a jumper between pins 1 and 2 of JP2 holds the AD1885 in reset, preventing it from driving signals to the serial port. When a jumper is between pins 2 and 3 of JP2, the AD1885 is held in reset until PF15 is set to an output and is asserted. These position are labeled on the board as “DIS” and “ENA 1885”.

4.3.3 Boot Mode Select Switch (SW1)

The boot mode select switch determines how the DSP will boot. [Table 4-2](#) shows the switch settings for the boot modes.

NOTE: SPI ROM is not available on the EZ-KIT Lite.

Table 4-2: Boot Mode Select Switch (SW1) Settings

BMODE0 Pin 1	BMODE1 Pin 2	BMODE2 Pin 3	Function
On	On	On	Execute from 16 bit external memory (no boot)
Off	On	On	Boot from 8-bit EPROM (Default)
On	Off	On	Boot from SPI0 ROM (8-bit addresses)
Off	Off	On	Boot from SPI0 ROM (16-bit addresses)
-	-	Off	All others reserved

4.3.4 DSP PLL Setup Switch (SW2)

The DSP’s Phase Lock Loop (PLL) multiplies the 20 MHz input clock by a multiplication factor to set the core clock speed of the DSP. Internal to the DSP the Programmable Flags, PF0-PF9, are multiplexed with the PLL setup signals, SSELO-6, DF, and MSEL0-1.

During reset, the function of these pins is to setup the PLL. At this time, these signals are attached to the PLL setup switch (SW2) and determine the core and external clock speeds of the DSP. Approximately 120uS after reset has been de-asserted these pins are no longer attached to SW2, but function as PFs.

The following table shows the switch position that corresponds to a DSP pin.

Table 4-3: PLL Setup Switch (SW2) Functions

DSP Pin	Switch Position
MSEL0	1
MSEL1	2
MSEL2	3
MSEL3	4
MSEL4	5
MSEL5	6
MSEL6	7
DF	8
SSEL0	9
SSEL1	10
None	11
Bypass	12

Figure 4-4 shows the default setting for SW2. This will produce a 300MHz core clock speed and a 120 MHz peripheral interface speed. For more information about setting up the multiplication factors, refer to the Managing DSP Clocks section of the *ADSP-21535 DSP Hardware Reference*.

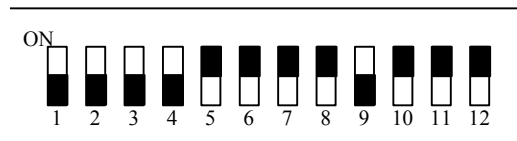

Figure 4-4: Default PLL Setup Switch Settings (SW2)

➤ **NOTE:** A switch setting of “ON” supplies a logic low (0) on the corresponding DSP pin.

4.4 LEDs and Push Buttons

This section describes the function of all the LEDs and push buttons. [Figure 4-5](#) shows the location of all the LEDs and push buttons.

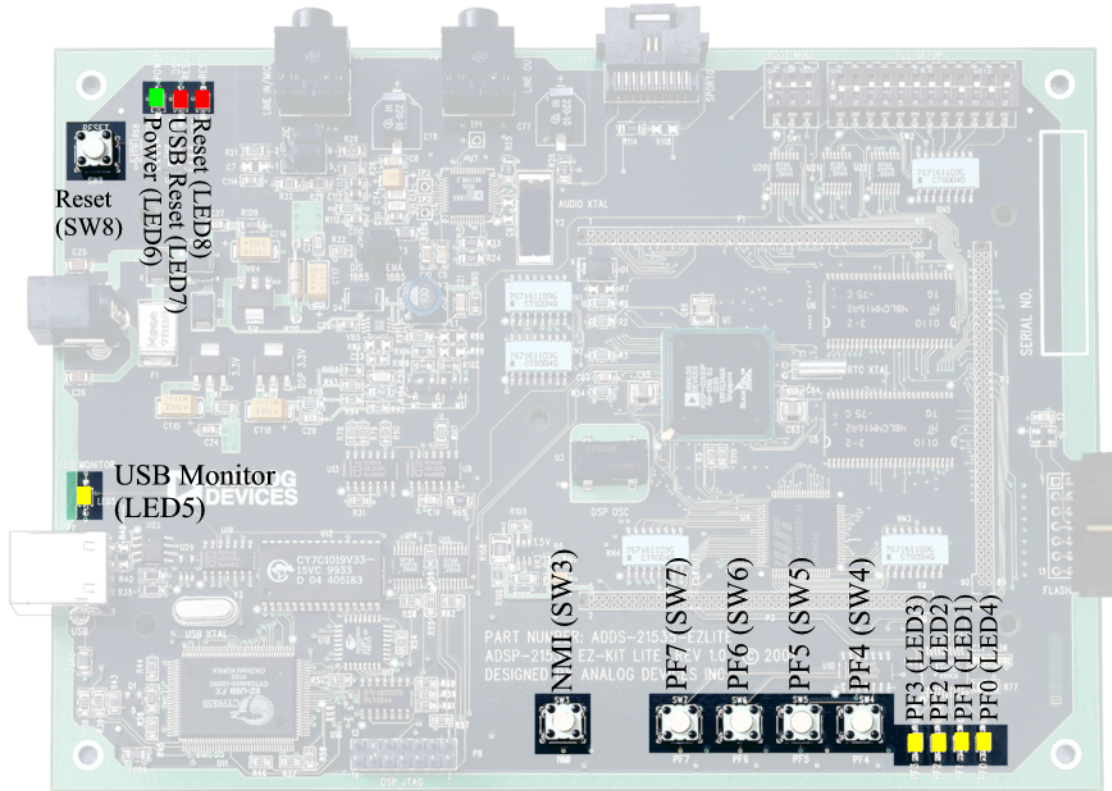

Figure 4-5: LED and Push Button Locations

4.4.1 Programmable Flag LEDs (LED1, LED2, LED3, LED4)

Four LEDs are connected to four of the DSP's Programmable Flag (PF) pins, PF0-3. These LEDs are active HIGH and are lit by an output of "1" from the DSP. Refer to section 3.6 for more information about using of the PFs when programming the DSP.

Table 4-4: Programmable Flag LEDs

LED Reference Designator	DSP Programmable Flag Pin
LED4	PF0
LED1	PF1
LED2	PF2
LED3	PF3

4.4.2 USB Monitor LED (LED5)

The USB Monitor LED (LED5) indicates that USB communication has been initialized successfully and you may connect to the DSP using a VisualDSP++ EZ-KIT Lite session. This should take approximately 15 seconds. If the LED does not light, try cycling power on the board and/or reinstalling the USB driver (see section 2.4.5).

4.4.3 Power LED (LED6)

LED6 is a green LED that indicates when power is being properly supplied to the board.

4.4.4 Reset LEDs (LED7, LED8)

When LED8 is lit, it indicates that the master reset of all the major ICs is active. When LED7 is lit, the USB interface chip (U11) is being reset. The USB chips will only reset on power-up, or if USB communication has not been initialized.

4.4.5 Non-Maskable Interrupt Push Button (SW3)

SW3 is connected to the Non-maskable Interrupt (NMI) pin of the DSP. When pressed, the DSP will vector to the NMI interrupt vector.

4.4.6 Programmable Flag Push Buttons (SW4, SW5, SW6, SW7)

Four push buttons are provided for general-purpose user input. SW4-7 connect to the DSP's Programmable Flag (PF) pins, PF4-7. The push buttons are active high and when pressed send a high (1) to the DSP. Refer to section 3.6 for more information about the use of the PFs when programming the DSP. Table 4-5 shows the PF signal and the switch it is connected to.

Table 4-5: Programmable Flag Switches

Push Button Reference Designator	DSP Programmable Flag Pin
SW4	PF4
SW5	PF5
SW6	PF6
SW7	PF7

4.4.7 Reset Push Button (SW8)

The RESET push button resets all of the ICs on the board. This reset does not affect the USB interface chip (U11) unless communication has not been initialized with a PC. After USB communication has been initialized, the only way to reset the USB is by powering down the board.

4.5 Connectors

This section describes the function of the connectors and gives information about mating connectors. The following figure shows the locations of the connectors.

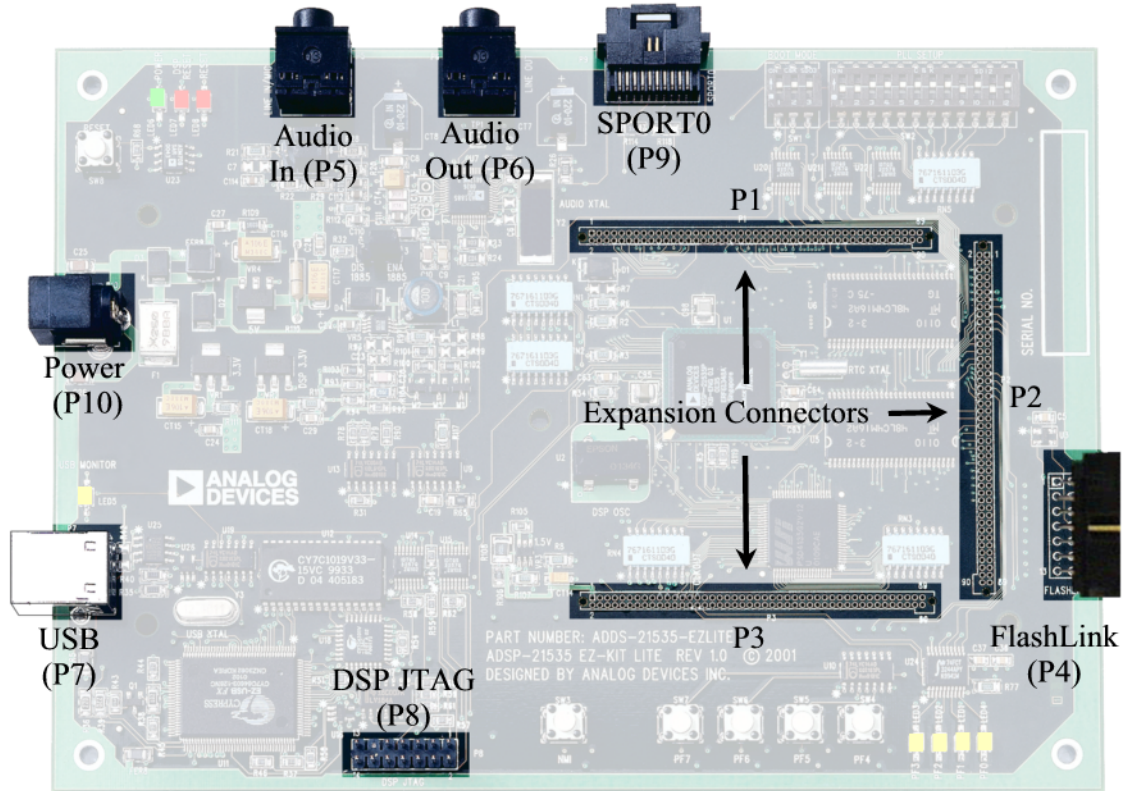

Figure 4-6: Connector Locations

4.5.1 Expansion Interface (P1, P2, P3)

Three board-to-board connector footprints provide the signals for most of the DSP peripheral interfaces. Analog Devices does not populate these connectors or provide any additional support for this interface. See section 4.2.3, for more information on the Expansion Interface. Contact Samtec for the availability and pricing of these connectors.

Part Description	Manufacturer	Part Number
90 Position 0.05" Spacing (P1, P2, P3)	Samtec	SFM-145-01-S-D
Mating Connector		
90 Position 0.05" Spacing (Through Hole)	Samtec	TFM-145-x1 Series
90 Position 0.05" Spacing (Surface Mount)	Samtec	TFM-145-x2 Series
90 Position 0.05" Spacing (Low Cost)	Samtec	TFC-145 Series

4.5.2 FlashLINK (P4)

The FlashLINK connector allows you to configure and program the STMicroelectronics DSM2150 flash/PLD chip. See section 3.5, for more information about using the FlashLINK connector.

Part Description	Manufacturer	Part Number
Right-angle 7X2 Shrouded 0.1 spacing	TYCO	2-767004-2
Mating Assembly		
FlashLINK™ JTAG Programmer	ST Micro	FL-101B

4.5.3 Audio (P5, P6)

There are two 3.5mm stereo audio jacks: one input, and one output.

Part Description	Manufacturer	Part Number
3.5mm stereo jack (P5, P6)	Shogyo	SJ-0359AM-5
Mating Cable		
3.5mm stereo plug to 3.5mm stereo cable	Radio Shack	42-2387A

4.5.4 USB (P7)

The USB connector is a standard Type B USB receptacle. This connector is used to debug the DSP, and is not connected to the DSP's USB interface.

Part Description	Manufacturer	Part Number
Type B USB receptacle (P7)	Mill-Max	897-30-004-90-000
	Digi-Key	ED90003-ND
Mating Connector		
USB cable (provided with kit)	Assmann	AK672-5
	Digi-Key	AK672-5ND

4.5.5 JTAG (P8)

The JTAG header is the connecting point for a JTAG in-circuit emulator pod. When an emulator is connected to the JTAG header, the USB debug interface is disabled.

- **NOTE: Pin 3 is missing to provide keying. Pin 3 in the mating connector should have a plug.**
- **NOTE: When using an emulator with the EZ-KIT Lite board, follow the connection instructions provided with the emulator.**

4.5.6 SPORT0 (P9)

SPORT0 is connected to a 20-pin connector. The pinout for this connector can be found in [APPENDIX B: SCHEMATIC](#). Contact AMP for pricing and availability on these connectors.

Part Description	Manufacturer	Part Number
20 position AMPMODU system 50 receptacle (P9)	AMP	104069-1
Mating Connectors		
20 position AMPMODU system 20 connector	AMP	2-487937-0
20 position AMPMODU system 20 connector (w/o lock)	AMP	2-487938-0
Flexible film contacts (20 per connector)	AMP	487547-1
Mating Assembly		
Straight-through assembly with locking connector on each end	Gopher Electronics	DRFFC10X7RHU- RHU5

4.5.7 Power Connector (P10)

The power connector provides all of the power necessary to operate the EZ-KIT Lite board.

Part Description	Manufacturer	Part Number
2.5mm Power Jack (P10)	Switchcraft	RAPC712
	Digi-key	SC1152-ND
Mating Power Supply (shipped with EZ-KIT Lite)		
7.5V Power Supply	GlobTek	TR9CC2000LCP-Y

4.6 Specifications

This section provides the requirements for powering the board and the mechanical dimensions of the board.

4.6.1 Power Supply

The power connector supplies DC power to the EZ-KIT Lite board. [Table 4-6](#) shows the power connector pinout.

Table 4-6: Power Connector

Terminal	Connection
Center pin	+7.5 VDC@2amps
Outer Ring	GND

4.6.2 Board Current Measurements

The ADSP-21535 EZ-KIT Lite board provides eight zero-ohm resistors that may be removed to measure current draw. [Table 4-7](#) shows the resistor number, the voltage plane, and a description of the components on the plane.

Table 4-7: Current Measurement Resistors

Resistor	Voltage Plane	Description
R2	VDD_RTC	DSP Real Time Clock Supply
R3	VDD_EXT	DSP External Interface Supply
R6	VDD_INT	DSP Internal Interface Supply
R7	VDD_PCIEXT	DSP PCI Interface Supply
R8	VDD_PLL	DSP Phase Lock Loop Supply
R110	5V	5V Supply
R111	3V	3V supply to all non DSP-related components
R113	3V_DSP	3V to DSP-related components

4.6.3 Mechanical Dimensions

The following figure shows the location of the mounting holes as well as the PIN1 of each of the expansion connectors.

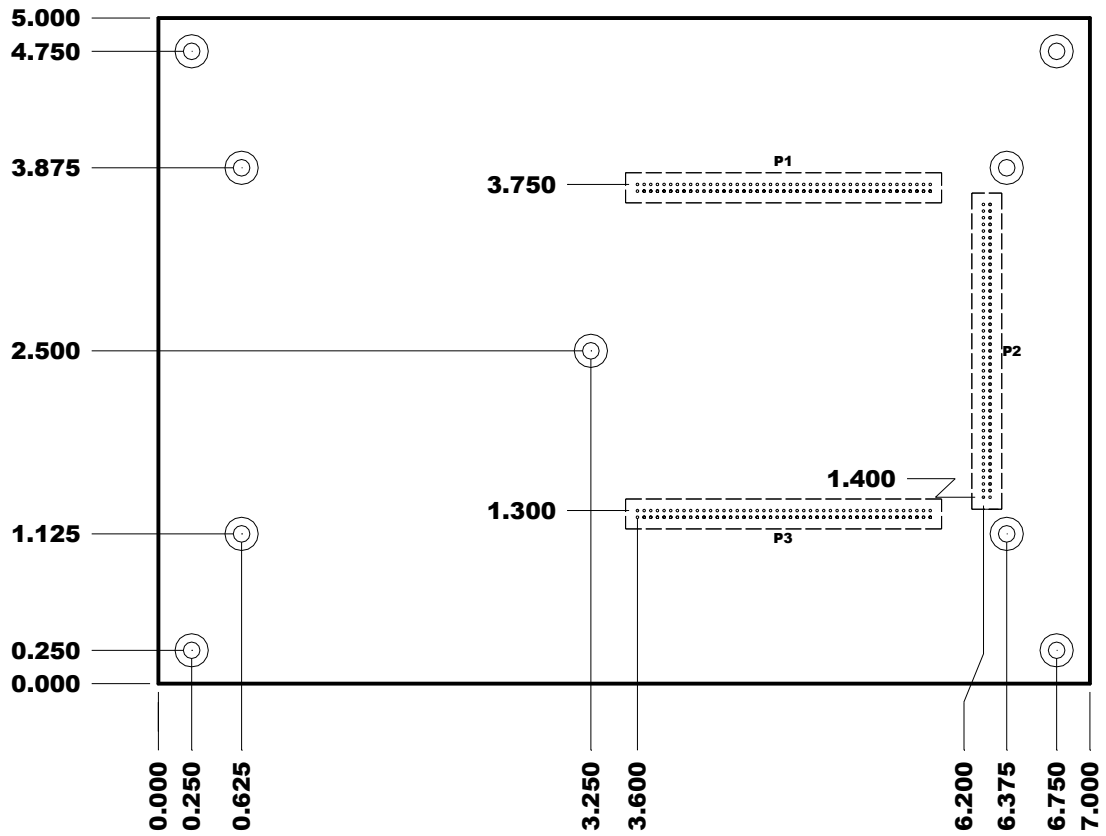

Figure 4-7: Mechanical Drawing

APPENDIX A: BILL OF MATERIALS

REF	QTY.	Description	Ref. Des	Manufacturer	Part Number
2	3	74LVC14A SOIC14 HEX-INVER-SCHMITT-TRIGGER	U9-10, U19	TI	74LVC14AD
3	1	IDT74FCT3244APY SSOP20 3.3V-OCTAL-BUFFER	U24	IDT	IDT74FCT3244APY
4	1	24.576MHZ SMT OSC005 CRYSTAL	Y2	EPSON	MA505 24.576M-C2
5	1	CY7C64603-128 PQFP128 USB-TX/RX MICROCONTROLLER	U11	CYPRESS	CY7C64603-128NC
6	1	MMBT4401 SOT-23 NPN TRANSISTOR 200MA	Q1	FAIRCHILD	MMBT4401
7	1	74LVC00AD SOIC14	U13	PHILIPS	74LVC00AD
8	1	24LC00-SN SOIC8 128 BIT SERIAL EEPROM	U25	MICROCHIP	24LC00-SN
9	1	ADP3331ART SOT23-6 ADJ 200MA REGULATOR	VR3	ANALOG DEVICES	ADP3331ART
10	3	BSS123 SOT23D NMOS FET	M1-3	FAIRCHILD	BSS123
11	1	CY7C1019BV33-15VC SOJ32 128K X 8 SRAM	U12	CYPRESS	CY7C1019BV33-12VC
12	1	SN74AHC1G02 SOT23-5 SINGLE-2 INPUT-NOR	U16	TI	SN74AHC1G02DBVR
13	1	SN74LV164A SOIC14 8-BIT-PARALLEL-SERIAL	U17	TI	SN74LV164AD
14	1	CY7C4201V-15AC TQFP32 64-BYTE-FIFO	U18	CYPRESS	CY7C4201V-15AC
15	1	12.0MHZ THR OSC006 CRYSTAL	Y3	DIG01	300-6027-ND
16	2	MT48LC4M16 TSOP54 4MX16-SDRAM-133MHZ	U5-6	MICRON	MT48LC4M16A2TG-75
17	1	32.768kHz TH OSC007 CRYSTAL	Y1	ECPLITEK	EC38T
18	1	SN74AHC1G00 SOT23-5 SINGLE-2-INPUT-NAND	U26	TI	SN74AHC1G00DBVR
19	1	21535 BRD DSM2150F5V U4"" BLKFIN160.OBJ SUM 876F5F1	U4		
20	2	1000pF 50V 5% 1206 CERM	C25-26	AVX	12065A102JAT2A
21	2	0.1uF 50V 10% 1206 CERM	C8-9	PHILIPS	12062R104K9BB2
22	1	ADM708SAR SOIC8 VOLTAGE-SUPERVISOR	U23	ANALOG	ADM708SAR
23	1	AD1885JST LQFP48 AC97 STEREO CODEC	U7		

24	2	ADP3338AKC-33 SOT-223 3.3V-1.0AMP REGULATOR	VR1-2	ANALOG	ADP3338AKC-3.3
25	1	ADP3339AKC-5 SOT-223 5V-1.5A REGULATOR	VR4	ANALOG	ADP3339AKC-5-REEL
26	1	ADP3088 MSOP8 500MA-BUCK-REGULATOR	VR5	ADI	ADP3088ARM-REEL
27	1	ADSP-21535PKB-300 PBGA260 308KBYTES-BLACKFIN	U1		
28	5	RUBBER FEET BLACK	MH1-5	MOUSER	517-SJ-5018BK
29	1	PWR 2.5MM_JACK CON005 RA	P10	SWITCHCRAFT	SC1152-ND12
30	1	USB 4PIN CON009 USB	P7	MILL-MAX	897-30-004-90-000000
31	1	.05 10X2 CON014 RA	P9	AMP	104069-1
32	6	SPST-MOMENTARY SWT013 6MM	SW3-8	PANASONIC	EVQ-PAD04M
33	1	DIP12 SWT014	SW2	DIGI-KEY	CKN3063-ND
34	1	DIP3 SWT015	SW1	DIGI-KEY	CKN3055-ND
35	1	IDC 7X2 IDC7X2SRDRA RIGHT ANGLE SHROUDED	P4	MOLEX	70247-1401
36	23	0.00 1/8W 5% 1206	R2-3,R6-12,R21,R63- 64,R77,R97,R111-118, 127	YAGEO	0.0ECT-ND
37	2	220uF 10V 20% E ELEC	CT7-8	SPRAGUE	293D227X9010E2T
38	5	AMBER-SMT LED001 GULL-WING	LED1-5	PANASONIC	LN1461C-TR
39	2	22pF 50V 5% 805 CERM	C5-C6	AVX	08055A220JAT
40	79	0.01uF 100V 10% 805 CERM	C19,C30-92,C94,C96- 97,C99-109,C116	AVX	08051C103KAT2A
41	1	0.22uF 25V 10% 805 CERM	C114	AVX	08053C224FAT
42	5	0.1uF 50V 10% 805 CERM	C3, C24, C27-29	AVX	08055C104KAT
43	4	10uF 16V 10% C TANT	CT15-18	SPRAGUE	293D106X9025C2T
44	44	10K 100MW 5% 805	R1,R13-19,R31- 32,R37,R44-45,R47- 54,R57,R59- 61,R66,R68,R78-81,	AVX	CR21-103J-T
45	44	10K 100MW 5% 805	R83-84,R87-88,R90- 93,R105,R120-122,R125	DALE	CRCW0805-103JRT1
46	4	33 100MW 5% 805	R4-5, R46, R119	AVX	CR21-330JTR
47	5	4.7K 100MW 5% 805	R55-56, R58, R62, R107	AVX	CR21-4701F-T
48	1	1M 100MW 5% 805	R41	AVX	CR21-1004F-T

49	1	1.5K 100MW 5% 805	R43	AVX	CR21-1501F-T
50	1	22uF 16V 10% D TANT	CT1	DIG01	PCT3226CT-ND
51	3	2.21K 1/8W 1% 1206	R30, R35, R40	AVX	CR32-2211F-T
52	4	10uF 16V 10% B TANT	CT4, CT19-21	AVX	TAJB106K016R
53	1	1A HSM160J DO-214AA SCHOTTKY	D4	MICRO-SEMI	HSM160J
54	5	100 100MW 5% 805	R67, R82, R85-86, R89	AVX	CR21-101J-T
55	1	1000 100MHZ 1.5A FER002 0.06 CHOKE	FER9	MURATA	PLM250S40T1
56	3	2A S2A_RECT DO-214AA SILICON RECTIFIER	D1-3	GENERALSEMI	S2A
57	8	600 100MHZ 500MA 1206 0.70 BEAD	FER1-8	DIGIKEY	240-1019-1-ND
58	1	0.047UF 16V 10% 1206	C10	AVX	12065C473JATME
59	2	270PF 50V 10% 805	C11, C13	KEMET	C1206C271J5GAC210
60	6	1UF 16V 10% 805 X7R	C4, C22, C110-113	MURATA	GRM40X7R105K016AL
61	6	470PF 100V 10% 1206 CERM	C12, C14-16, C20-21	AVX	12061A471JAT2A
62	2	30PF 100V 5% 1206	C17-18	AVX	12061A300JAT2A
63	3	10UF 25V +80-20% 1210 Y5V	C93, C95, C98	MURATA	GRM235Y.5V106Z025
64	1	0.47UF 20V 10% A TANT	CT14	KEMET	T491A474K025AS
65	1	16K 1/8W5% 1206	R65	DALE	CRCW1206-163JRT1
66	1	53.6K 1/10W 1% 805	R95	PHILIPS	9C08052A5362FKRT/R
67	1	165K 1/10W 1% 805	R102	PHILIPS	9C08052A1653FKRT/R
68	1	316K 1/10W 1% 805	R103	PHILIPS	9C08052A3163FKRT/R
69	1	332K 1/10W 1% 805	R101	PHILIPS	9C08052A3323FKRT/R
70	1	665K 1/10W 1% 805	R100	PHILIPS	9C08052A6653FKRT/R
71	1	10UH 47+/-20 IND001	L1	TDK	SLF7045T-100M1R1-2
72	1	243.0K 1/10W 1% 805	R106	PHILIPS	9C08052A2433FKRT/R
73	1	1.00M 1/4W 1% 1210	R108	PANASONIC/EC G	ERJ-14NF1004U
74	3	10K 31MW 5% RNET8	RN6-8	CTS	746X101103J

75	2	39PF 50V 5% 805 NPO	C1-C2	PANASONIC	ECJ-2VC1H390J
76	5	10K 100MW 2% RNET16 BUSSED	RN1-5	CTS	767-161-103G
77	1	1K 1/8W 5% 1206	R38	AVX	CR32-102J-T
78	6	10K 1/8W 5% 1206	R23-27, R33	DALE	CRCW1206-1002FRT1
79	1	100K 1/8W 5% 1206	R109		CR1206-1003FTR1
80	1	20.0K 1/8W 1% 1206	R104		
81	3	22 1/8W 5% 1206	R36,R39, R126		
82	7	270 1/8W 5% 1206	R69-73, R75-76	AVX	CR32-271J-T
83	4	4.7K 1/8W 5% 1206	R20, R22, R28-29	AVX	CR32-472J-T
84	1	680 1/8W 5% 1206	R74	AVX	CR32-681J-T
85	1	20MHZ 1/2 OSC001	U2	ECLIPTEK	EC1100HS-20.000MHZ
86	2	RED-SMT LED001 GULL-WING	LED7-8	PANASONIC	LN1261C
87	1	GREEN-SMT LED001 GULL-WING	LED6	PANASONIC	LN1361C
88	5	1uF 25V 20% A TANT -55+125	CT9-13	PANASONIC	ECS-T1EY105R
89	5	QS3257Q QSOP16 QUICKSWITCH-257	U14-15, U20-22	ANALOG DEV.	ADG774ABRQ
90	1	IDC 3X1 IDC3X1	JP2	BERG	54101-T08-03
91	1	IDC 3X2 IDC3X2	JP1	BERG	54102-T08-03
92	1	IDC 7X2 IDC7X2	P8	BERG	54102-T08-07
93	3	IDC 2PIN_JUMPER 0.1	SJ1-3	MOLEX	15-38-1024
94	1	2.5A RESETABLE FUS001	F1	RAYCHEM CORP.	SMD250-2
95	2	3.5MM STEREO_JACK CON001	P5-6		

APPENDIX B: SCHEMATIC

A

B

C

D

1

1

2

2

ADSP-21535 EZ-KIT LITE

3

3

4

4

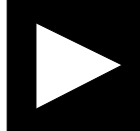
 ANALOG DEVICES	20 Cotton Road Nashua, NH 03063 PH: 1-800-ANALOGD		
	Title ADSP-21535 EZ-KIT LITE - TITLE		
Size C	Board No.	A0162-2000	Rev 1.4
Date	5-3-2002_12:31	Sheet	1 of 10

Approvals	Date
Drawn	5/11/02
Checked	
Engineering	

A

B

C

D

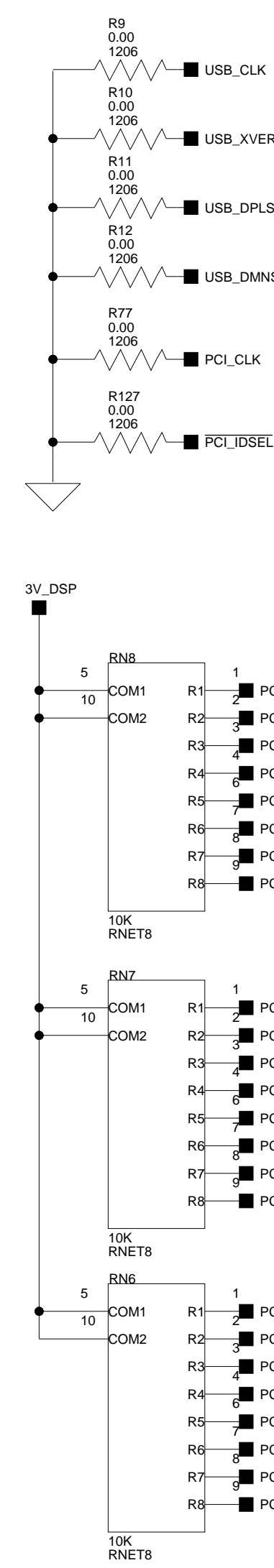
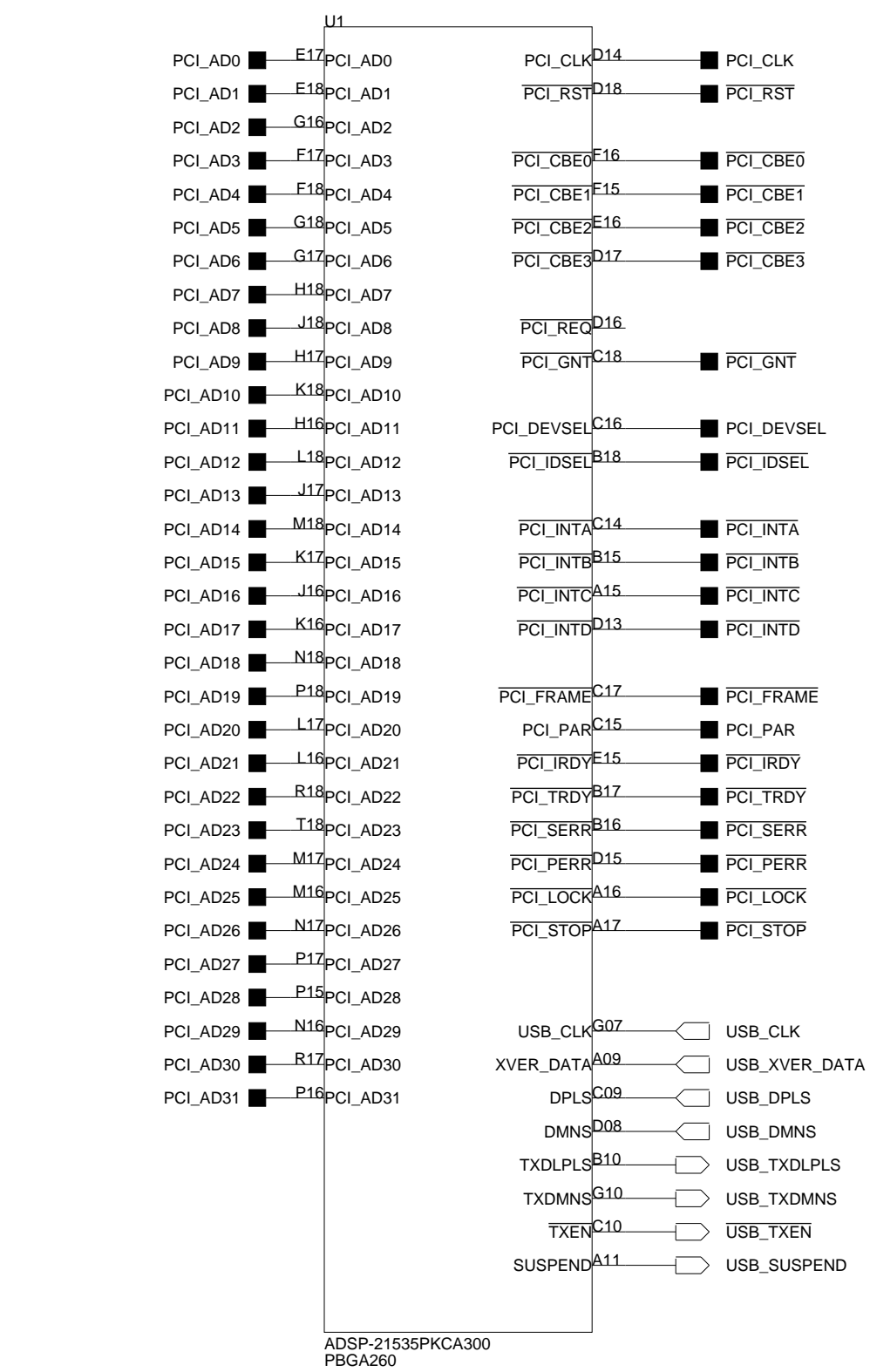
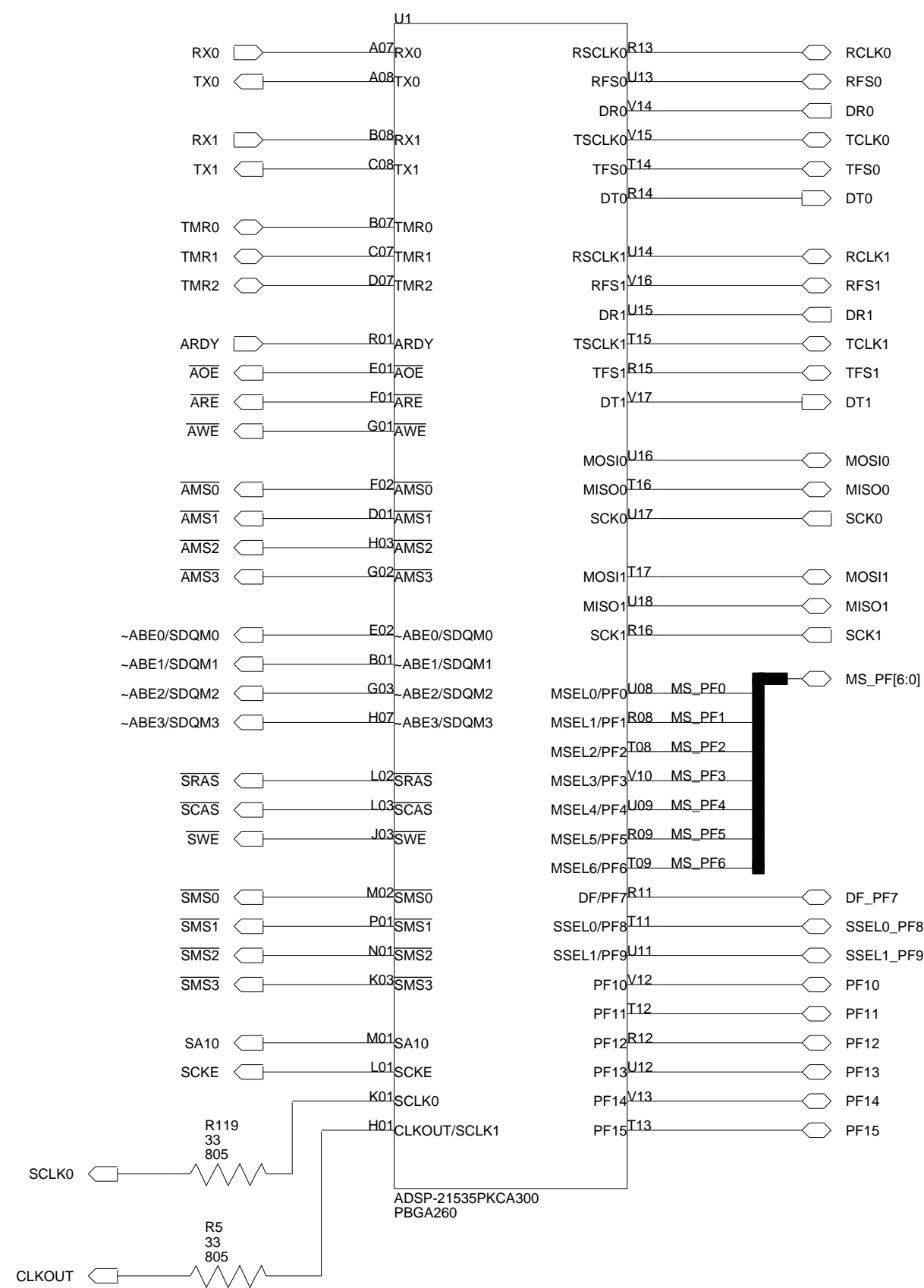
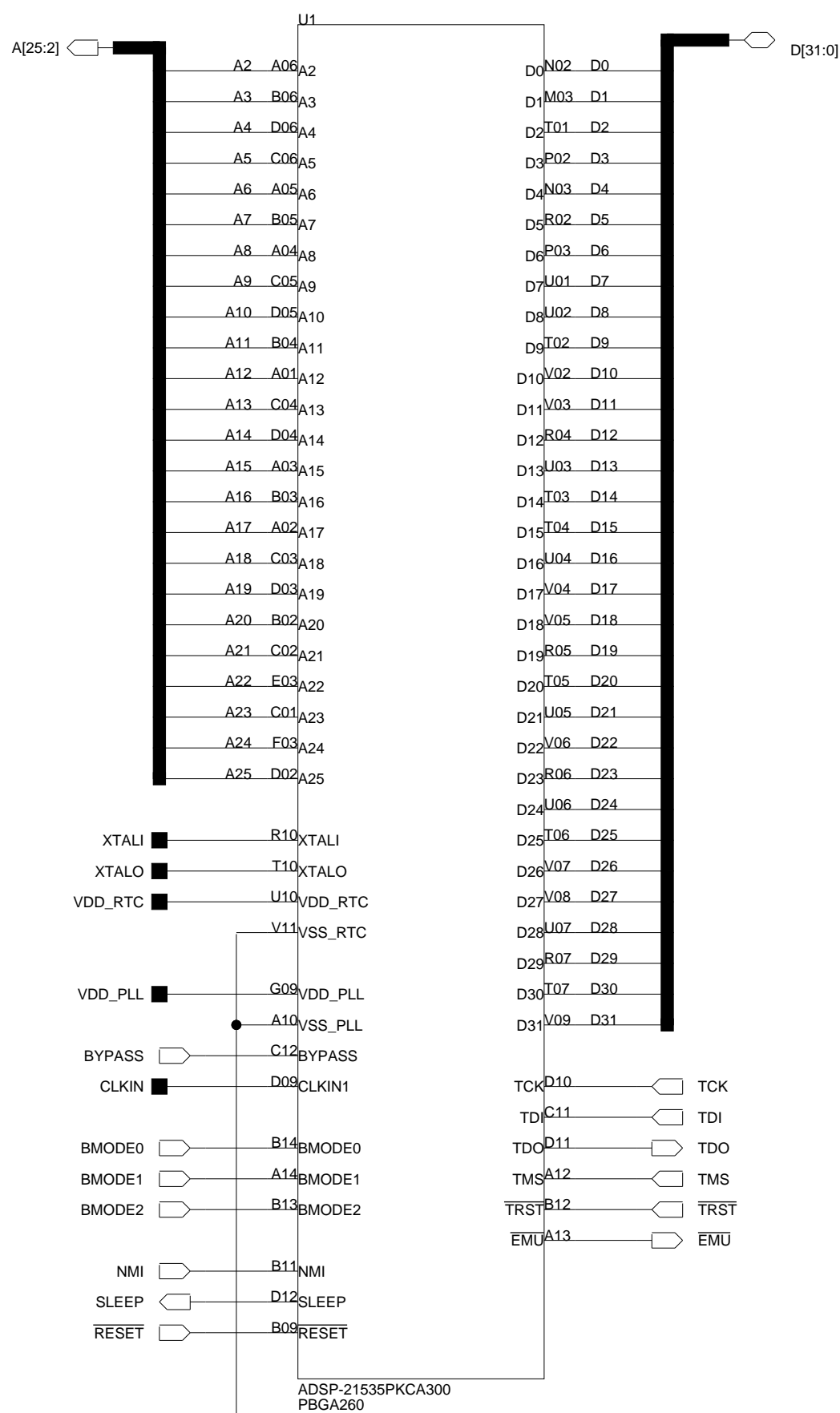
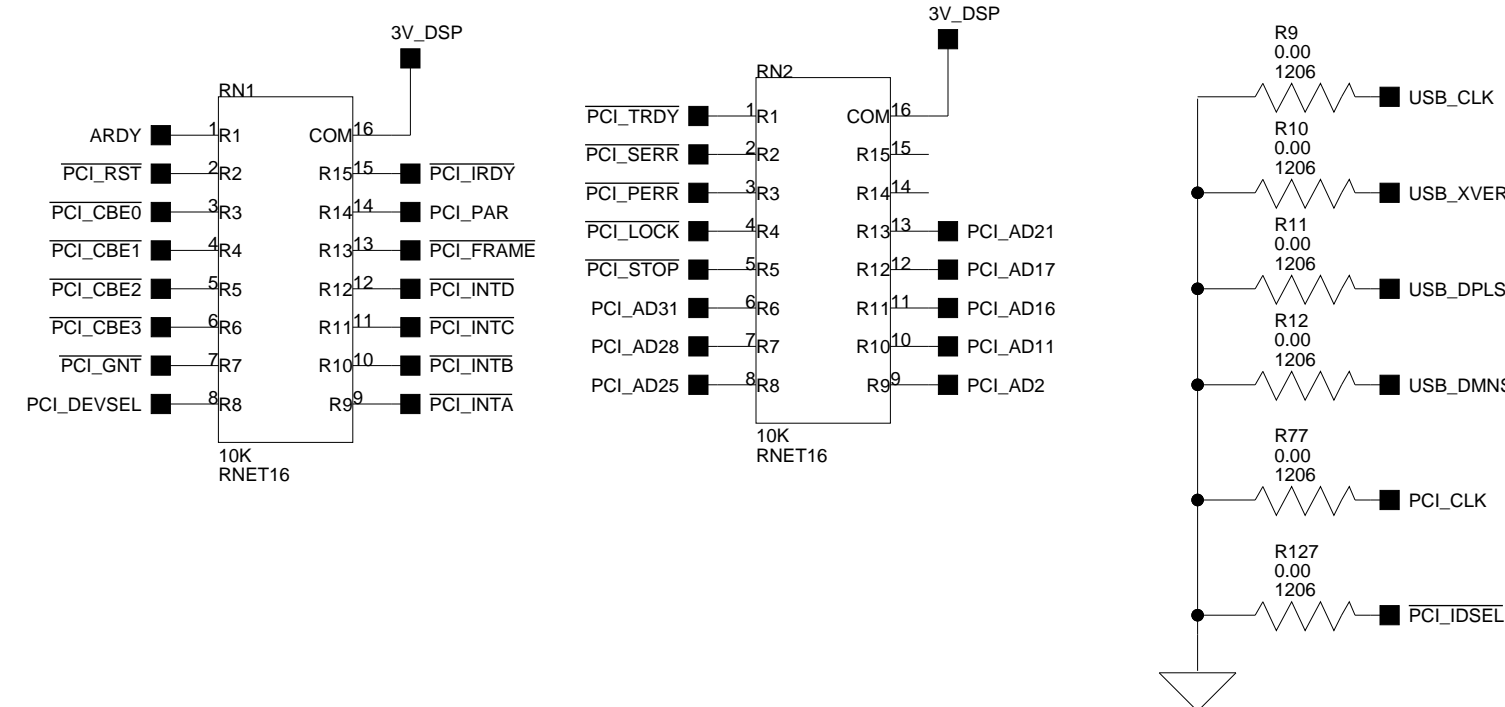
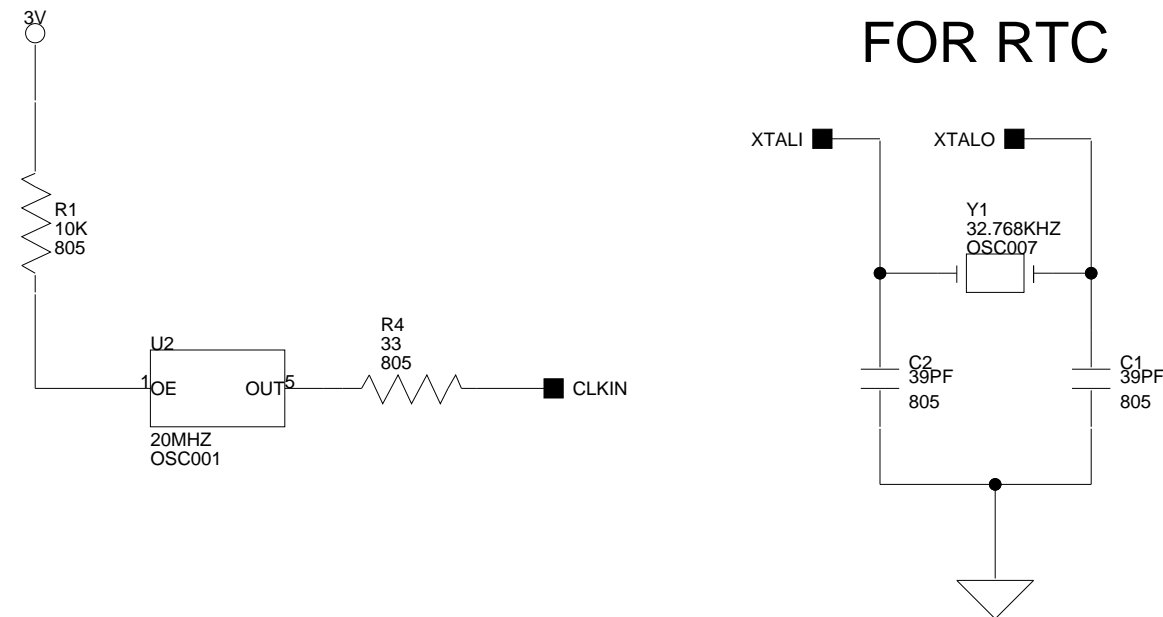
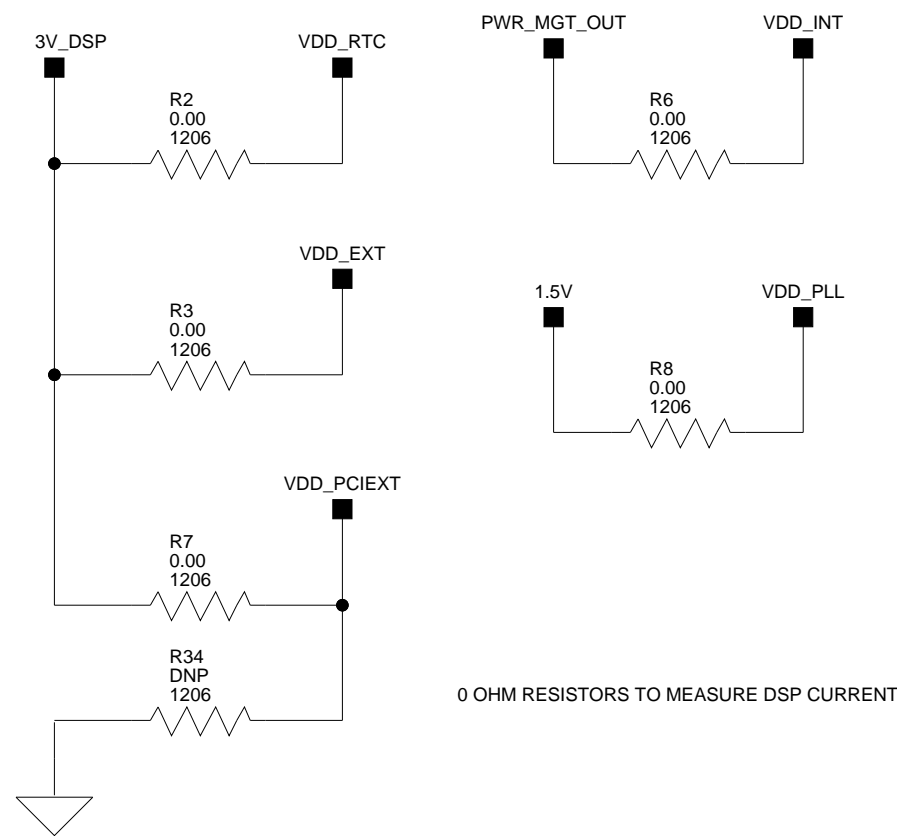

ANALOG DEVICES

20 Cotton Road
Nashua, NH 03063
PH: 1-800-ANALOGD

Approvals		Date		Title	
Drawn		5/11/02		ADSP-21535 EZ-KIT LITE - DSP	
Checked		Engineering		Size C	Board No. A0162-2000
Engineering		Date		5-3-2002_12:31	Rev 1.4
Sheet				of	
2				10	

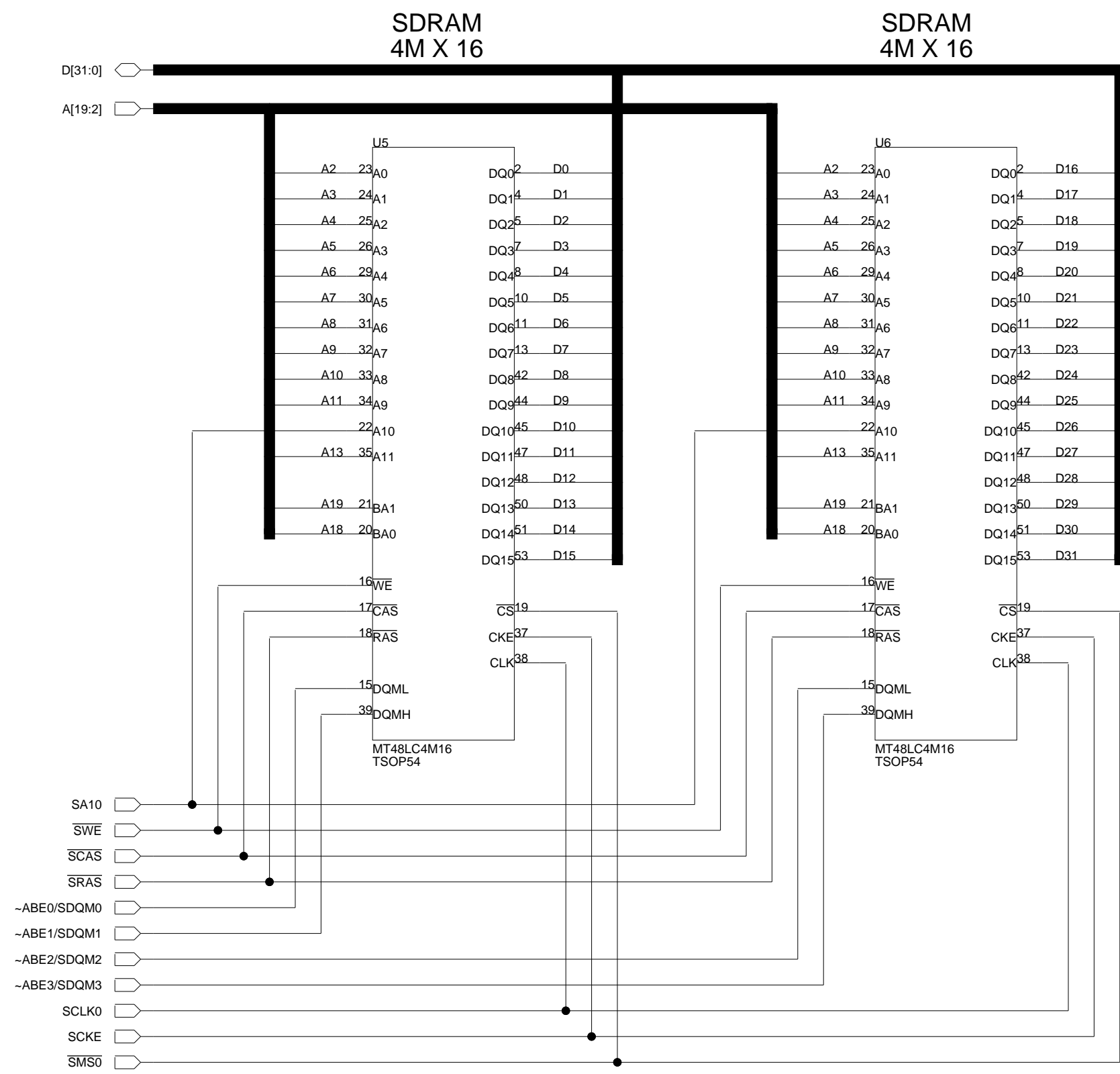
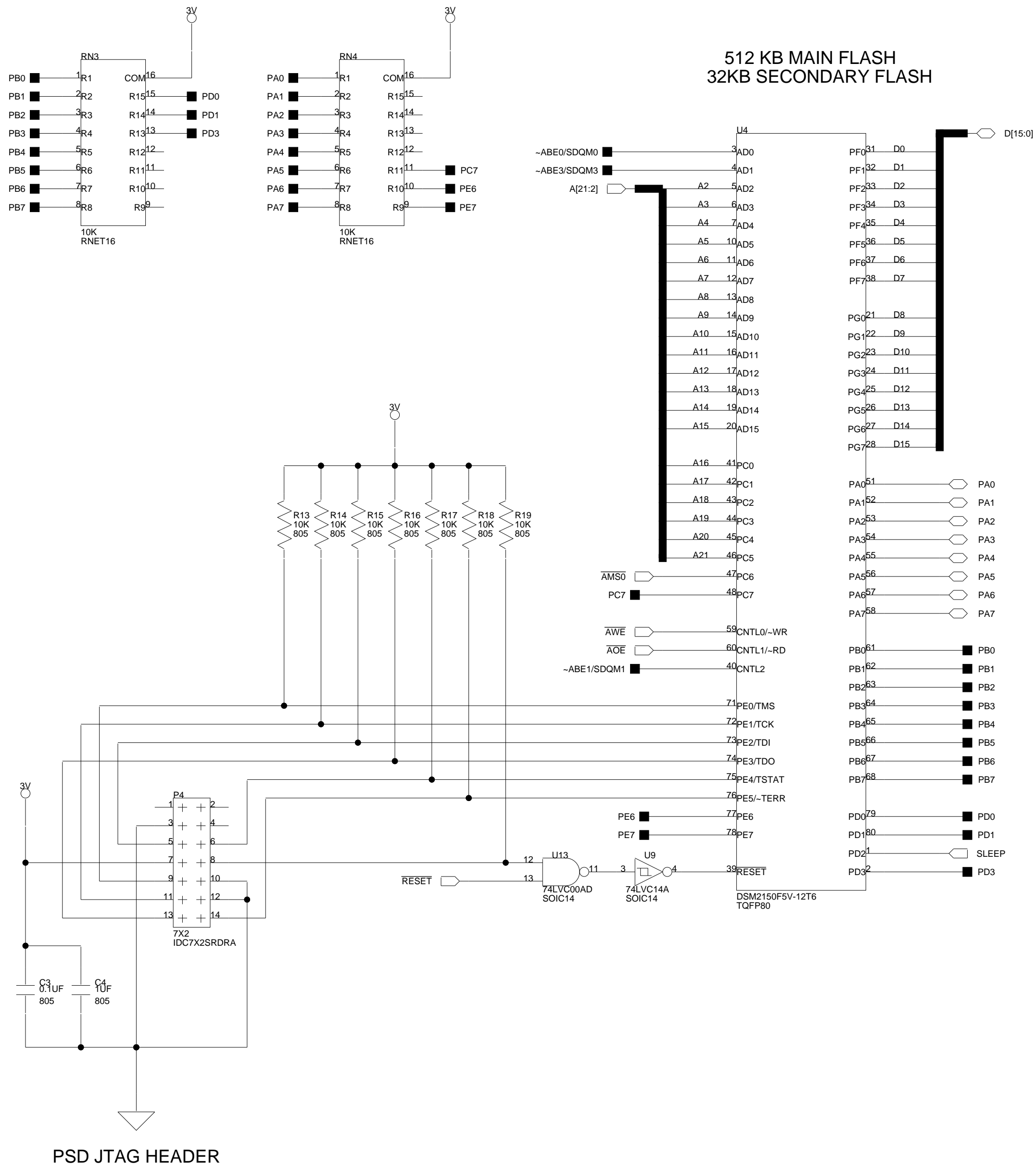

		20 Cotton Road Nashua, NH 03063 PH: 1-800-ANALOGD	
		Title ADSP-21535 EZ-KIT LITE - DSP MEMORY	
Approvals Drawn Checked Engineering	Date 5/11/02	Size C Board No. A0162-2000	Rev 1.4
Date 5-3-2002_12:31		Sheet 3 of 10	

SJ2
SHORTING JUMPER
DEFAULT=4 & 6

SJ1
SHORTING JUMPER
DEFAULT=3 & 5

JP1 SETTINGS

SJ1	SJ2	INPUT SOURCE
1 & 3	2 & 4	MIC IN
3 & 5	4 & 6	LINE IN

* Denotes Default Setting

POPULATE TO COMPLY WITH PC99

**AUDIO CODEC
AD1885**

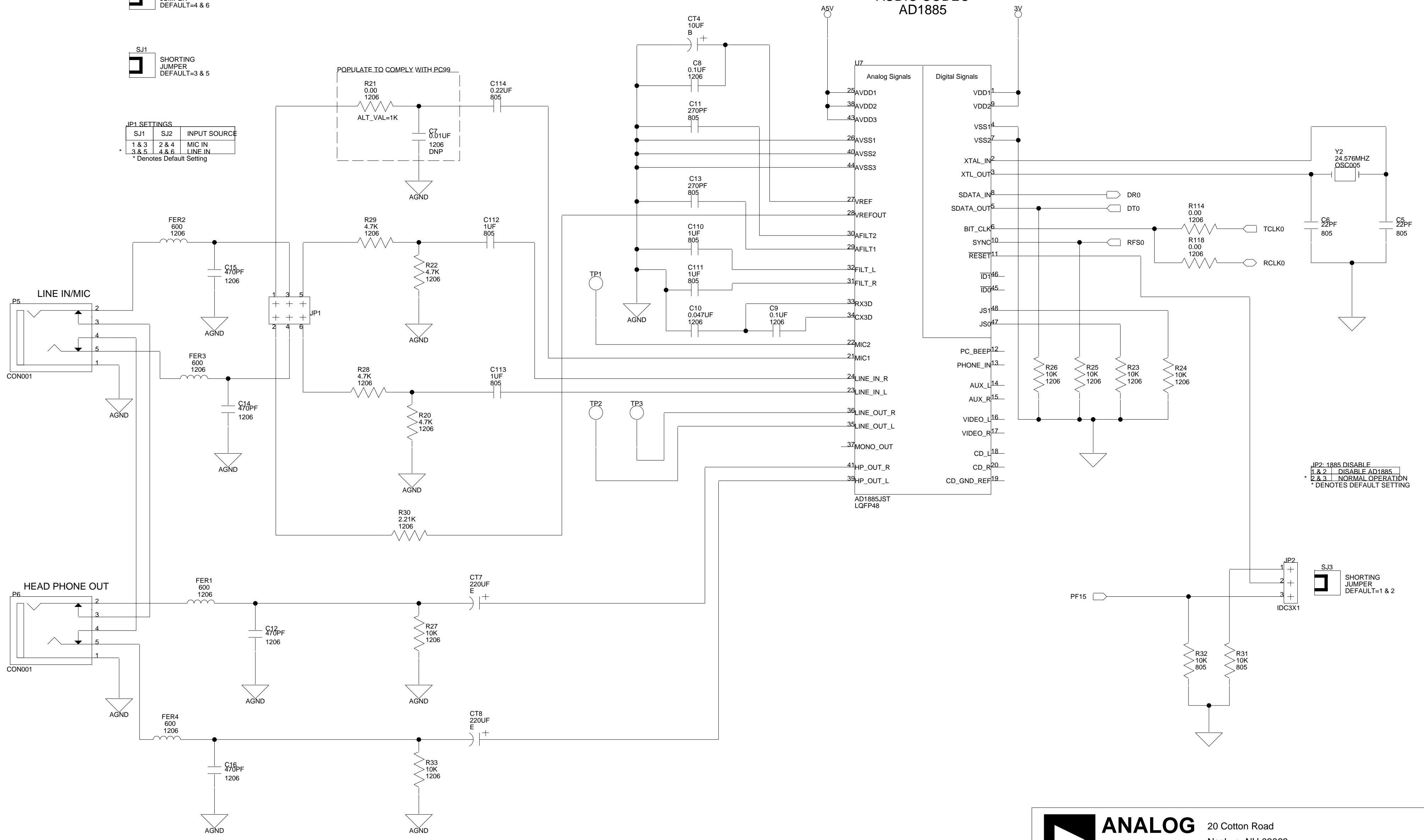

JP2- 1885 DISABLE

1 & 2	DISABLE AD1885
2 & 3	NORMAL OPERATION

* DENOTES DEFAULT SETTING

SJ3
SHORTING JUMPER
DEFAULT=1 & 2

ANALOG DEVICES

20 Cotton Road
Nashua, NH 03063
PH: 1-800-ANALOGD

Approvals		Date		Title	
		5/11/02		ADSP-21535 EZ-KIT LITE - AUDIO CODEC	
Drawn				Size C	
				Board No.	
Checked				A0162-2000	
				Rev	
Engineering				1.4	
				Date	
		5-3-2002_12:31		Sheet	
				4 of 10	

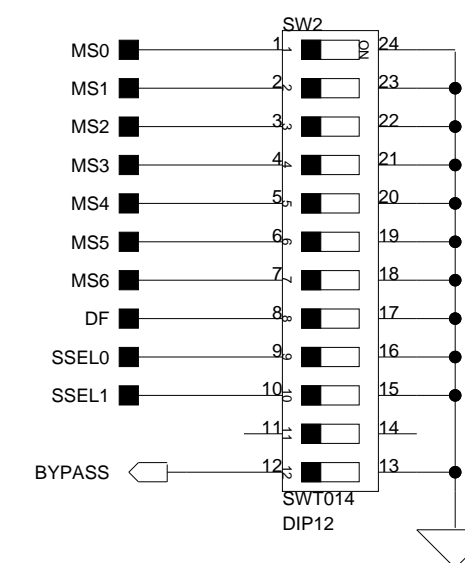
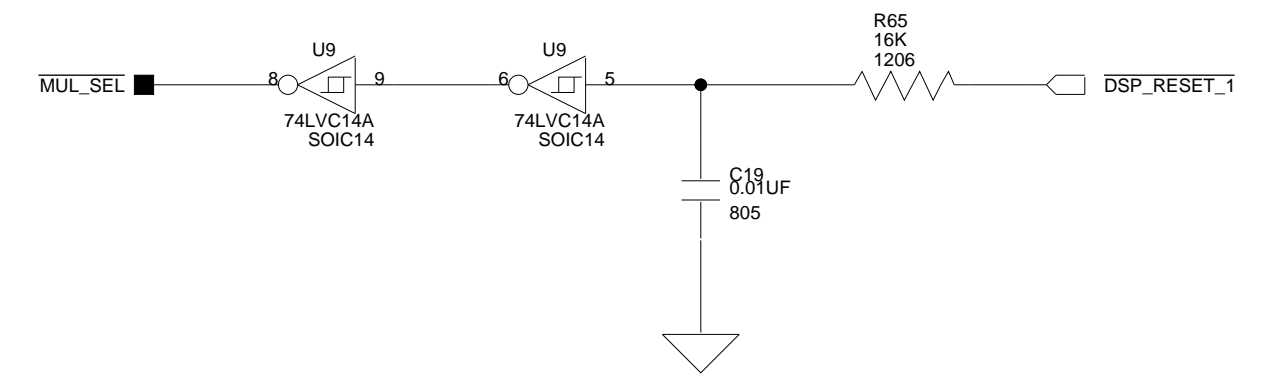
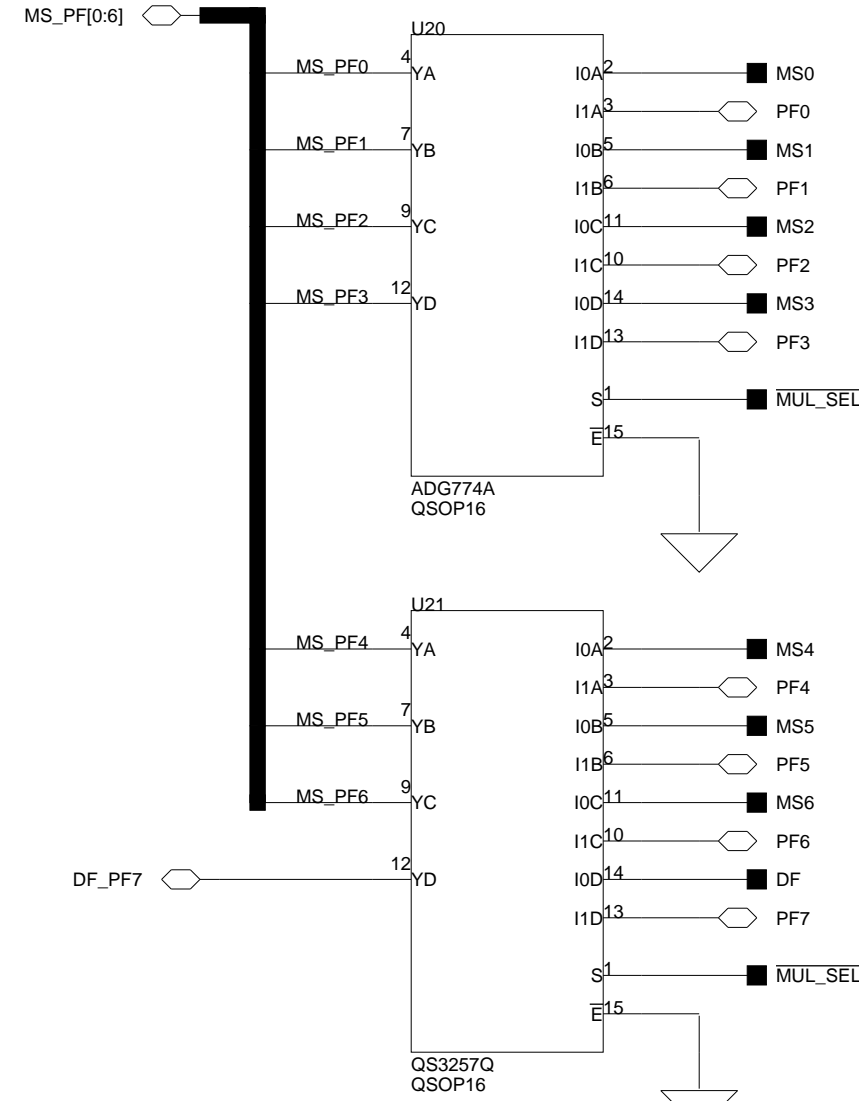
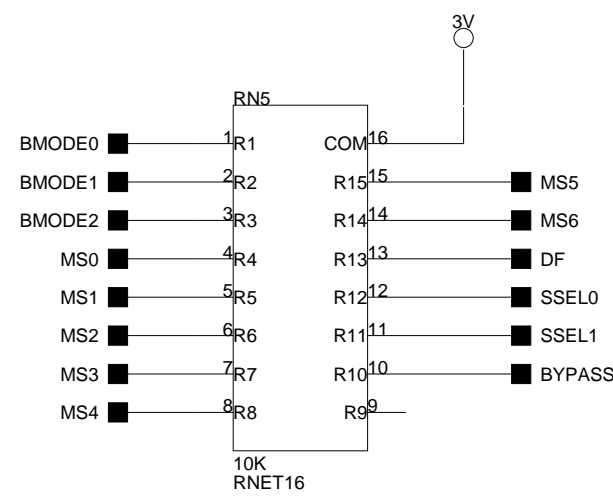

SW2: CLOCK MULTIPLIER SELECT SWITCH											
1	2	3	4	5	6	7	8	9	10	11	12
OFF	OFF	OFF	OFF	OFF	ON	ON	ON	ON	OFF	ON	ON

DEFAULT SETTINGS:
 Internal Clock - 15:1 - 300MHZ
 External Clock - 2.5:1 - 120MHZ

REFER TO DSP HARDWARE REFERENCE FOR DETAILED SETTING INFORMATION

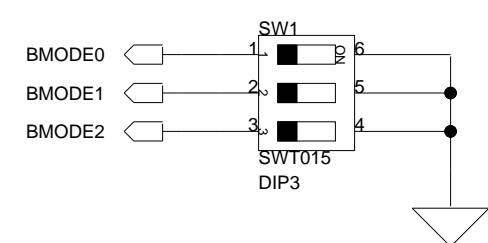

SW1 SETTINGS: BOOT MODE SELECTION			
BMODE2	BMODE1	BMODE0	BOOT MODE
ON	ON	ON	EXECUTE 16-BIT EXTERNAL 8-BITS ROM
ON	ON	OFF	SPI0 ROM (8-BIT ADDRESS)
ON	OFF	ON	SPI0 ROM (16-BIT ADDRESS)
OFF	OFF	OFF	ALL OTHERS RESERVED

* = DEFAULT

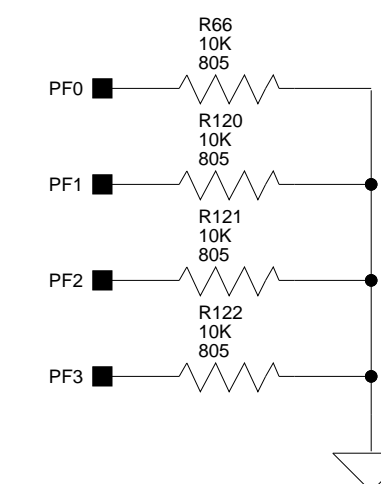
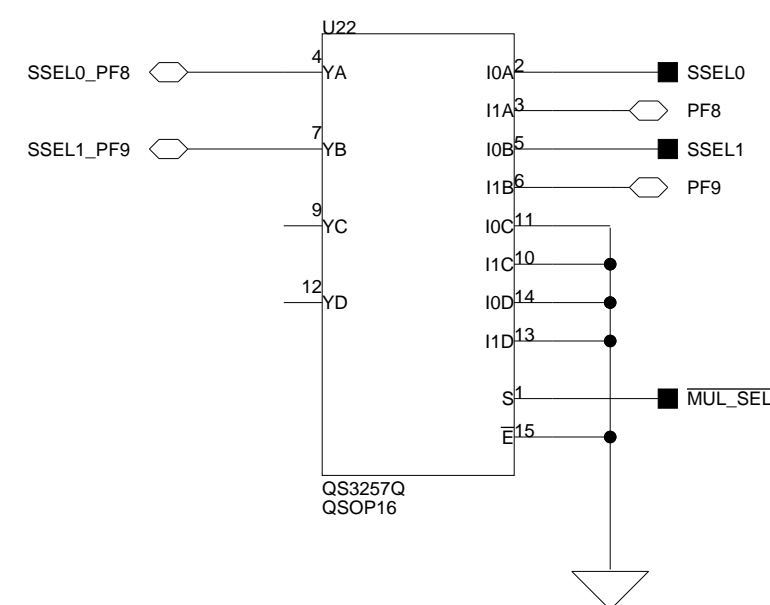

ANALOG DEVICES

20 Cotton Road
 Nashua, NH 03063
 PH: 1-800-ANALOGD

Approvals		Date		Title	
		5/11/02		ADSP-21535 EZ-KIT LITE - CONFIG	
Drawn				Size	
				C	
Checked				Board No.	
				A0162-2000	
Engineering				Rev	
				1.4	
Date				Sheet	
5-3-2002_12:31				5 of 10	

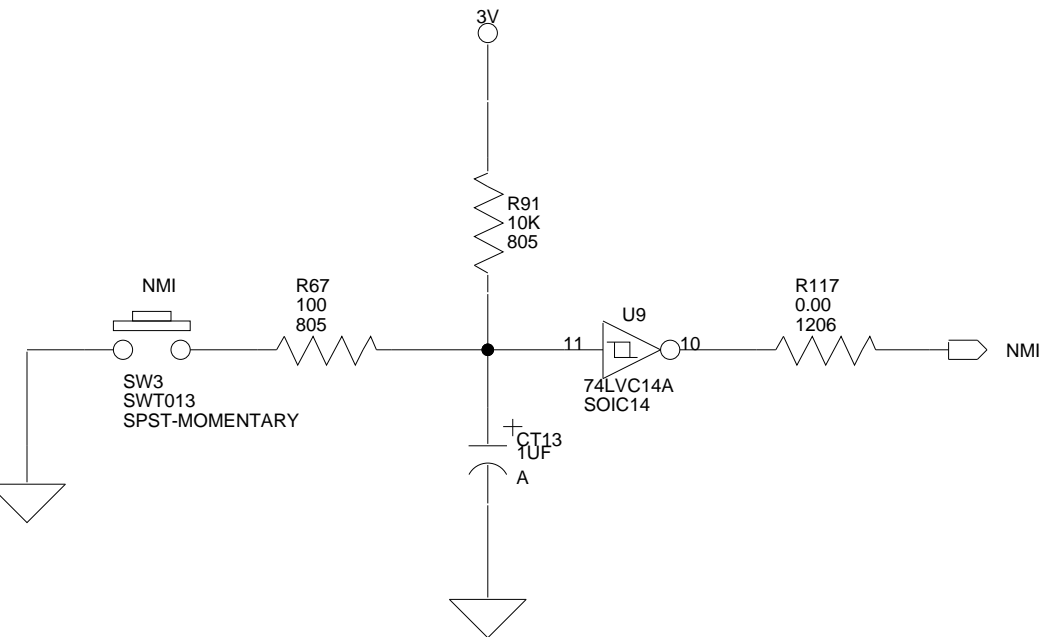
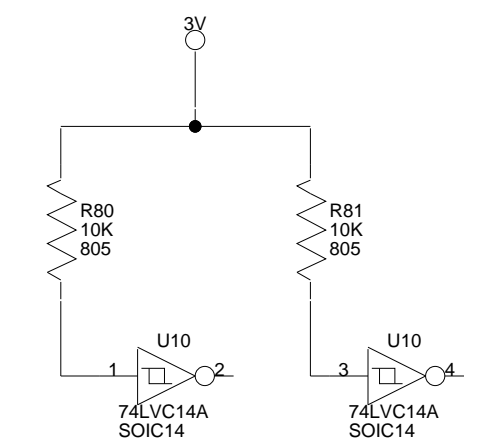
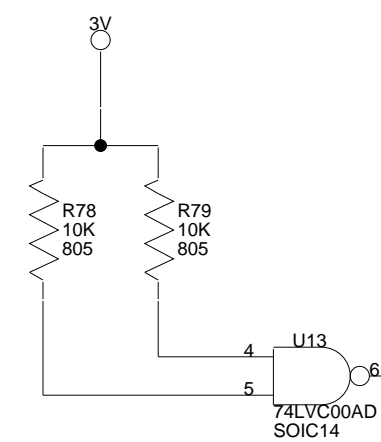
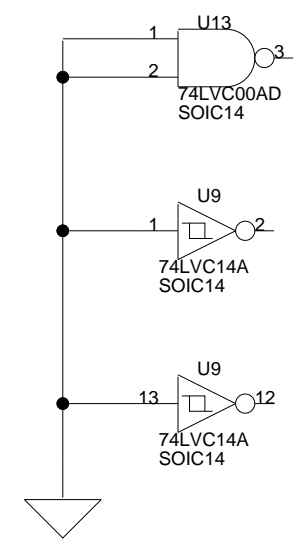
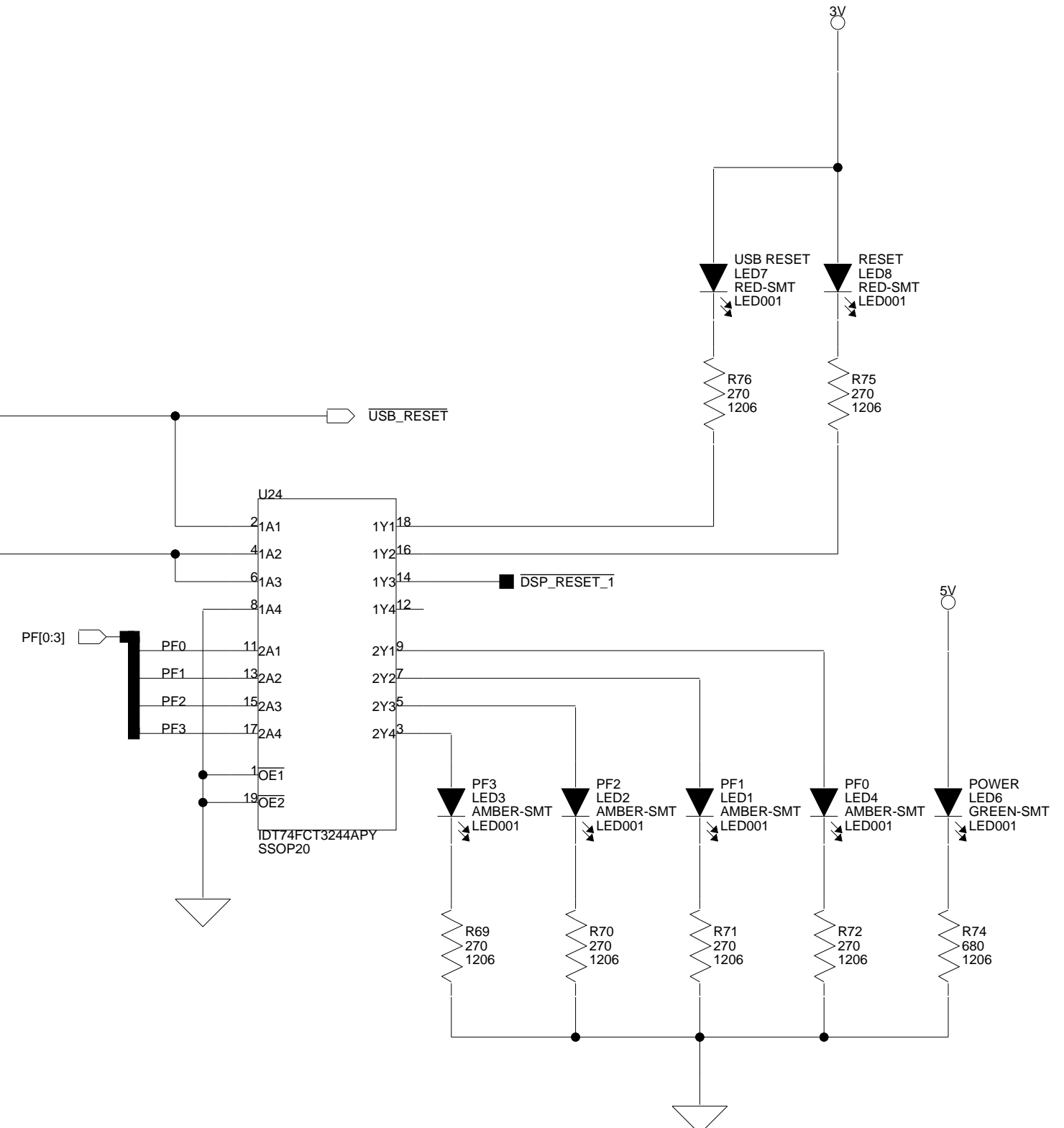
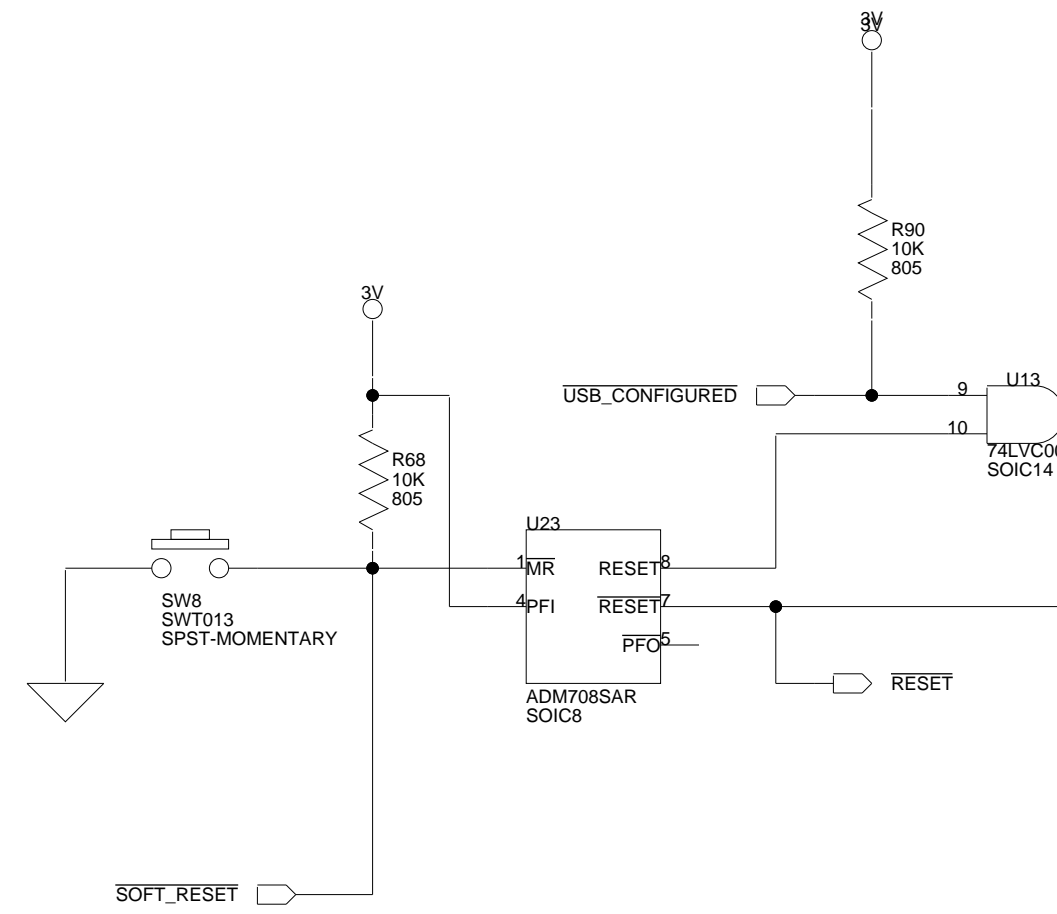
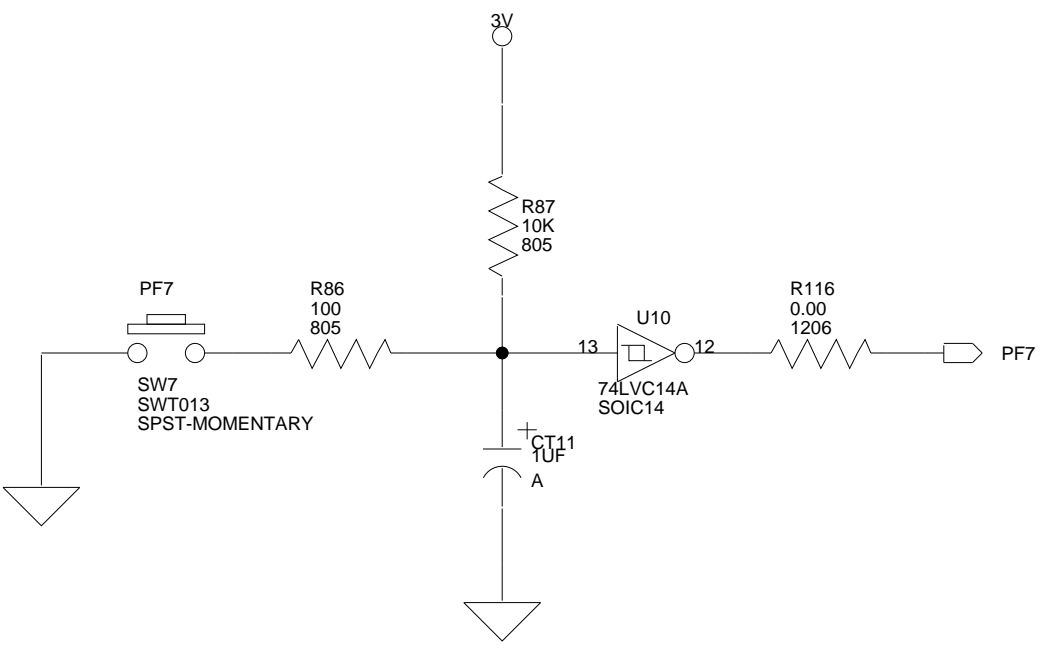
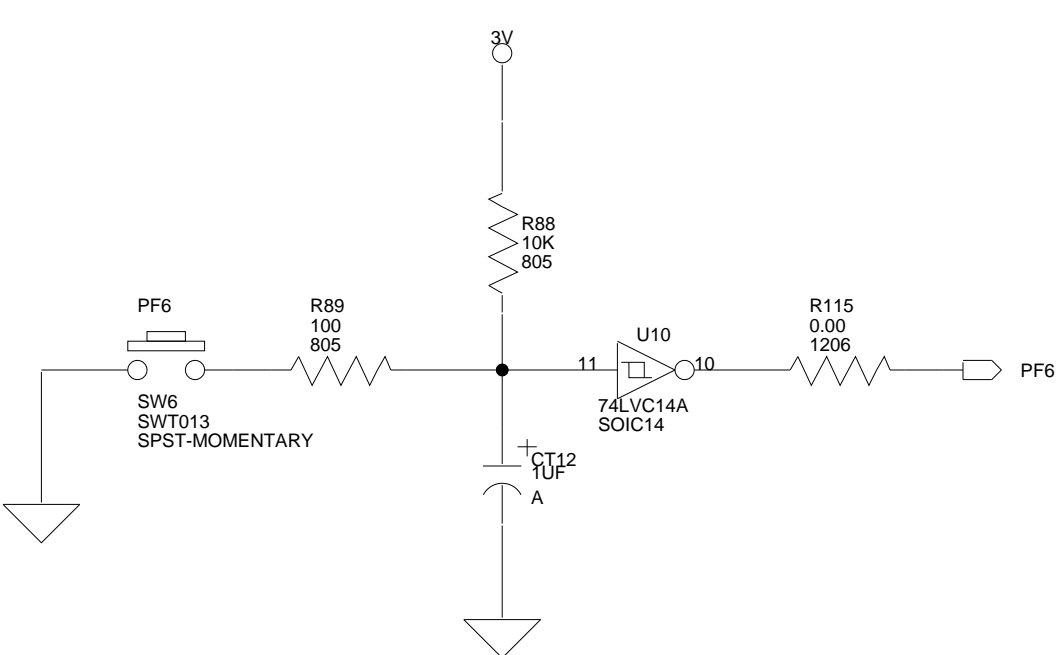
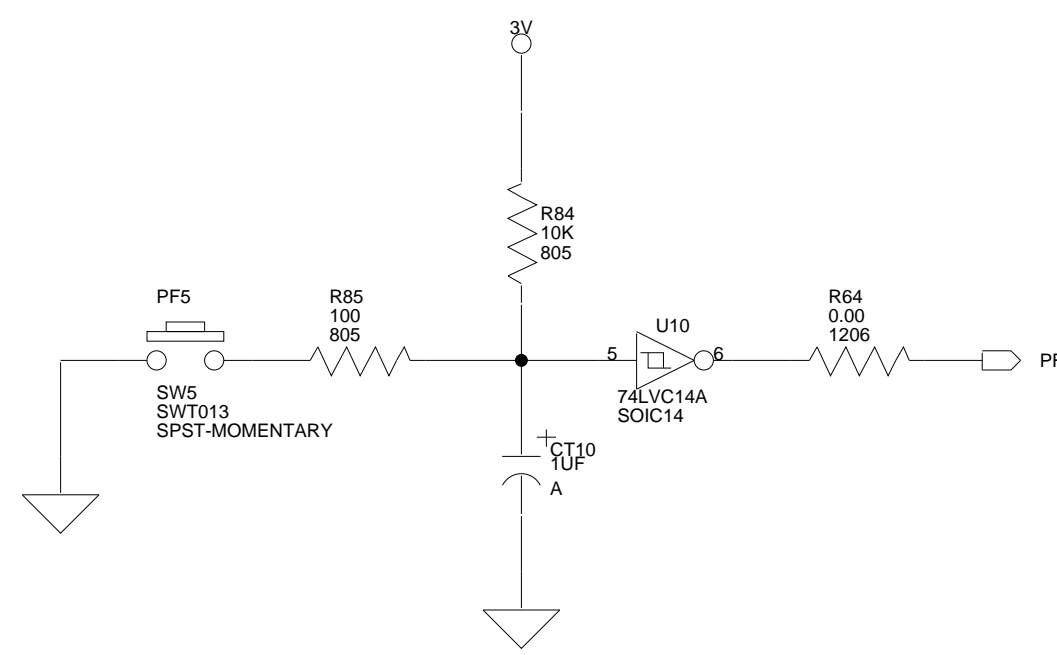
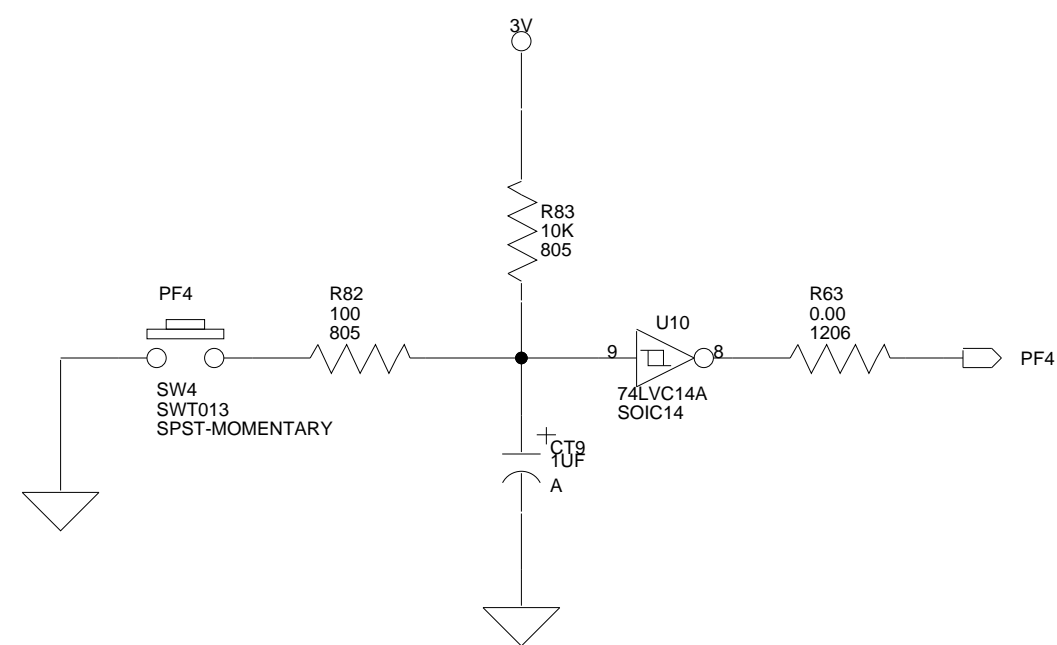

		20 Cotton Road Nashua, NH 03063 PH: 1-800-ANALOGD		
		Title ADSP-21535 EZ-KIT LITE - RESET/PB/LED		
Approvals	Date 5/11/02	Size C	Board No. A0162-2000	Rev 1.4
Drawn	Checked	Date 5-3-2002_12:31	Sheet 6 of 10	
Engineering				

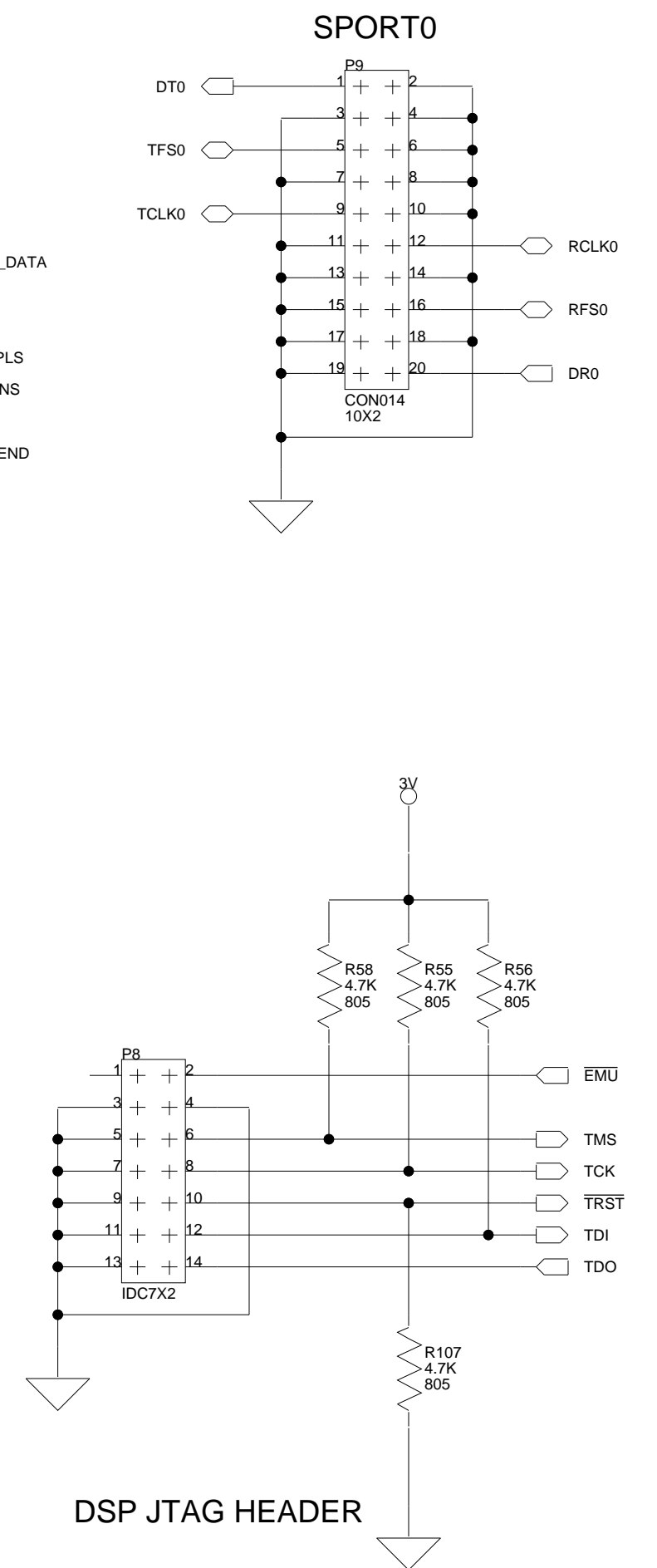
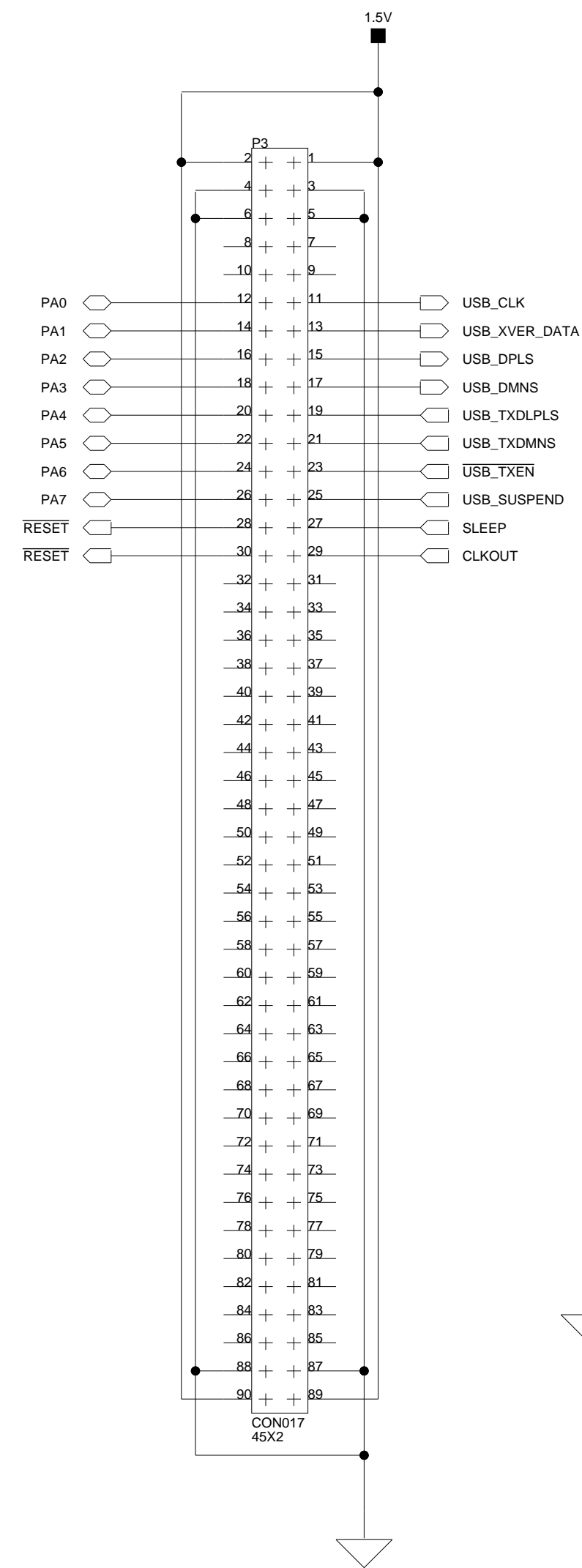
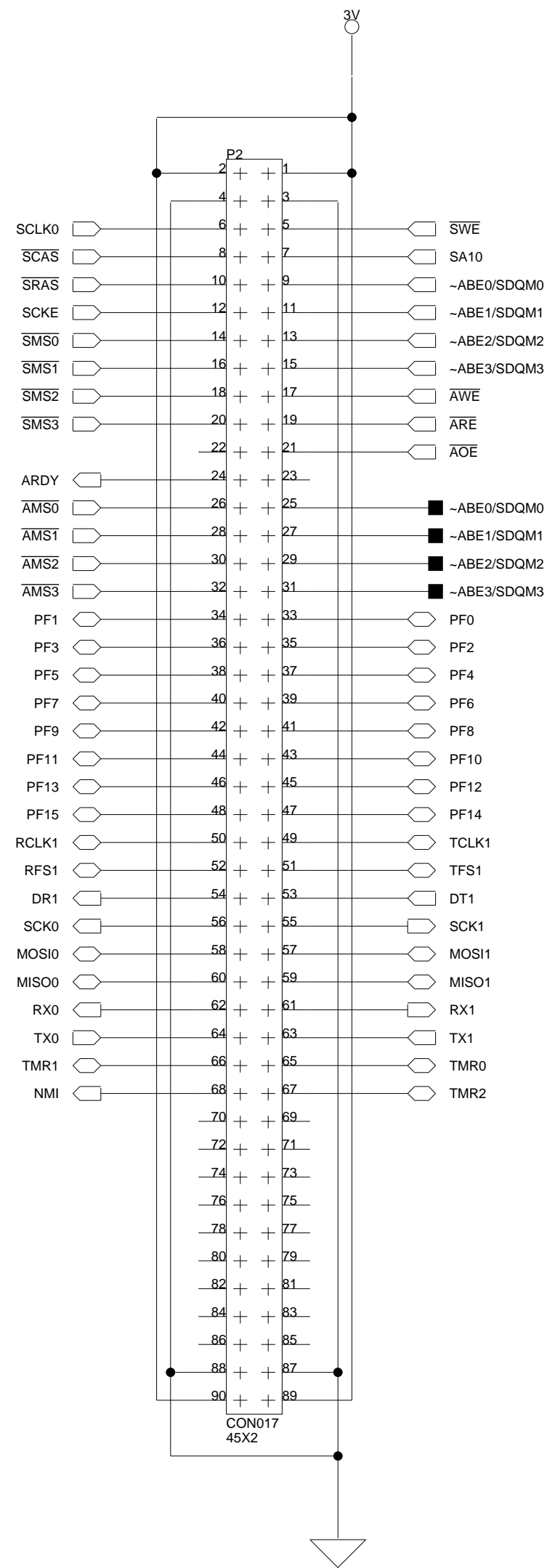
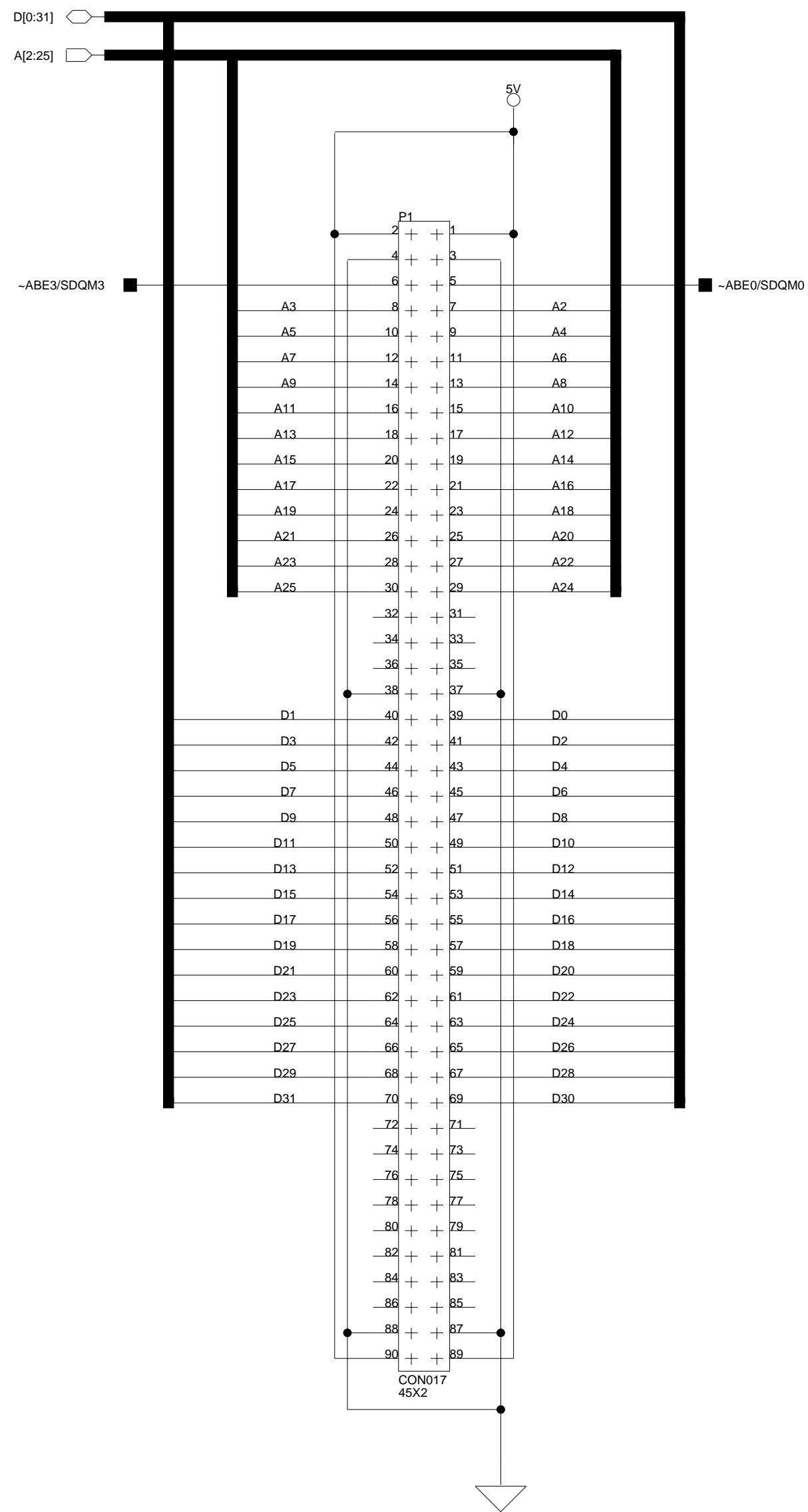

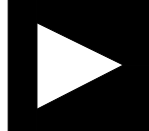
 ANALOG DEVICES 20 Cotton Road Nashua, NH 03063 PH: 1-800-ANALOGD		Title		ADSP-21535 EZ-KIT LITE - CONNECTORS	
		Size C	Board No.	A0162-2000	
Date		5-3-2002_12:31		Sheet 7 of 10	

Approvals	Date
Drawn	5/11/02
Checked	
Engineering	

PF14	PF13	PF12	VDD_INT
1	1	1	1.6V
1	1	0	1.5V *
1	0	1	1.4V
1	0	0	1.3V
0	1	1	1.2V
0	1	0	1.1V
0	0	1	1.0V
0	0	0	0.9V

* = DEFAULT
 WAIT 100uS FOR VOLTAGE TO SETTLE
 AFTER CHANGING PF11-9

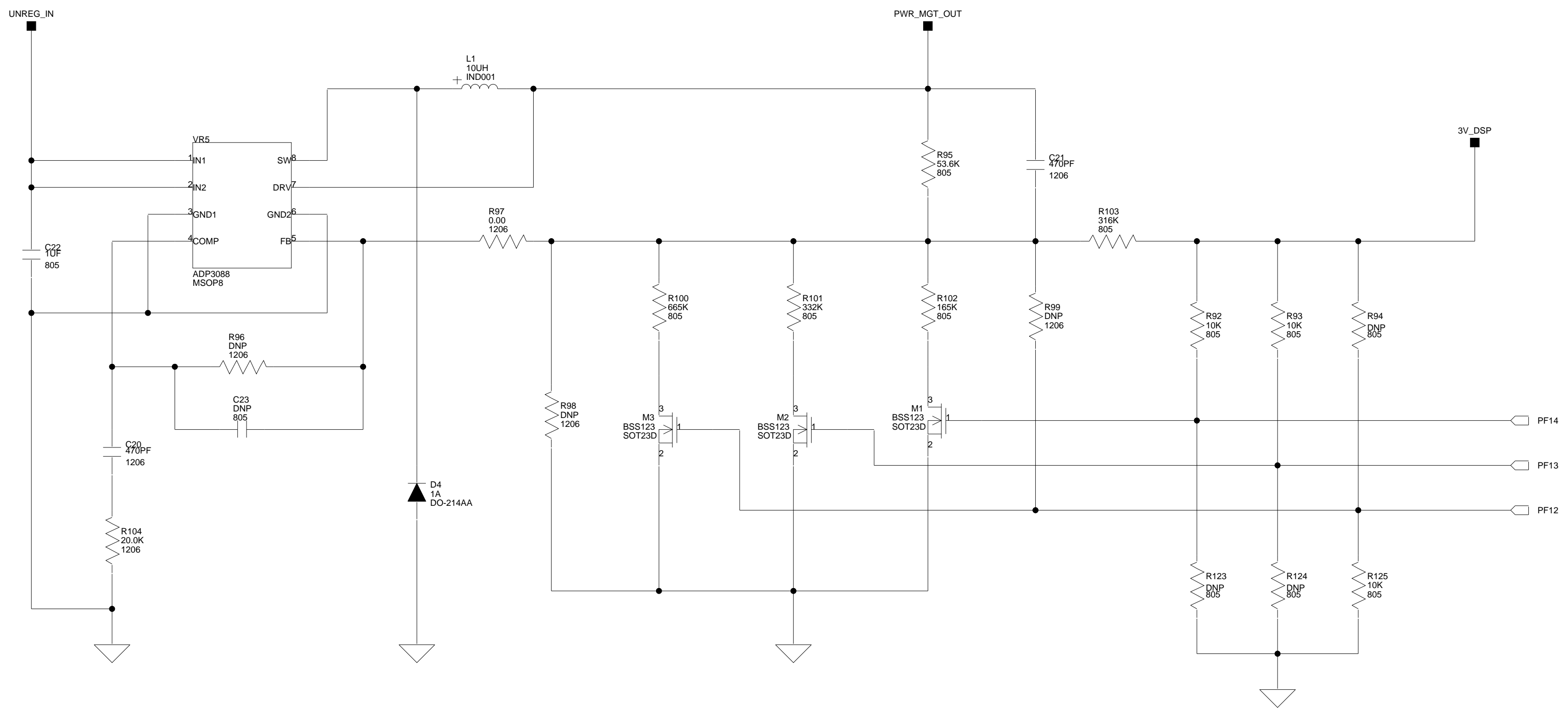

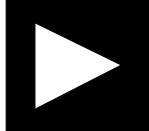
 ANALOG DEVICES 20 Cotton Road Nashua, NH 03063 PH: 1-800-ANALOGD		Title		ADSP-21535 EZ-KIT LITE - POWER 1	
		Size	Board No.	A0162-2000	
Date		5-3-2002_12:31		Sheet 8 of 10	

Approvals	Date
Drawn	5/11/02
Checked	
Engineering	

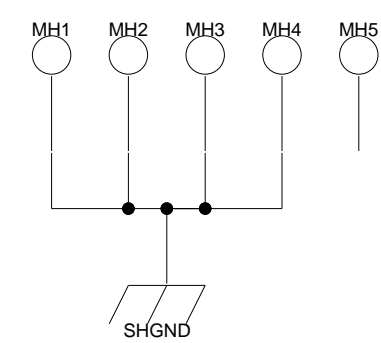
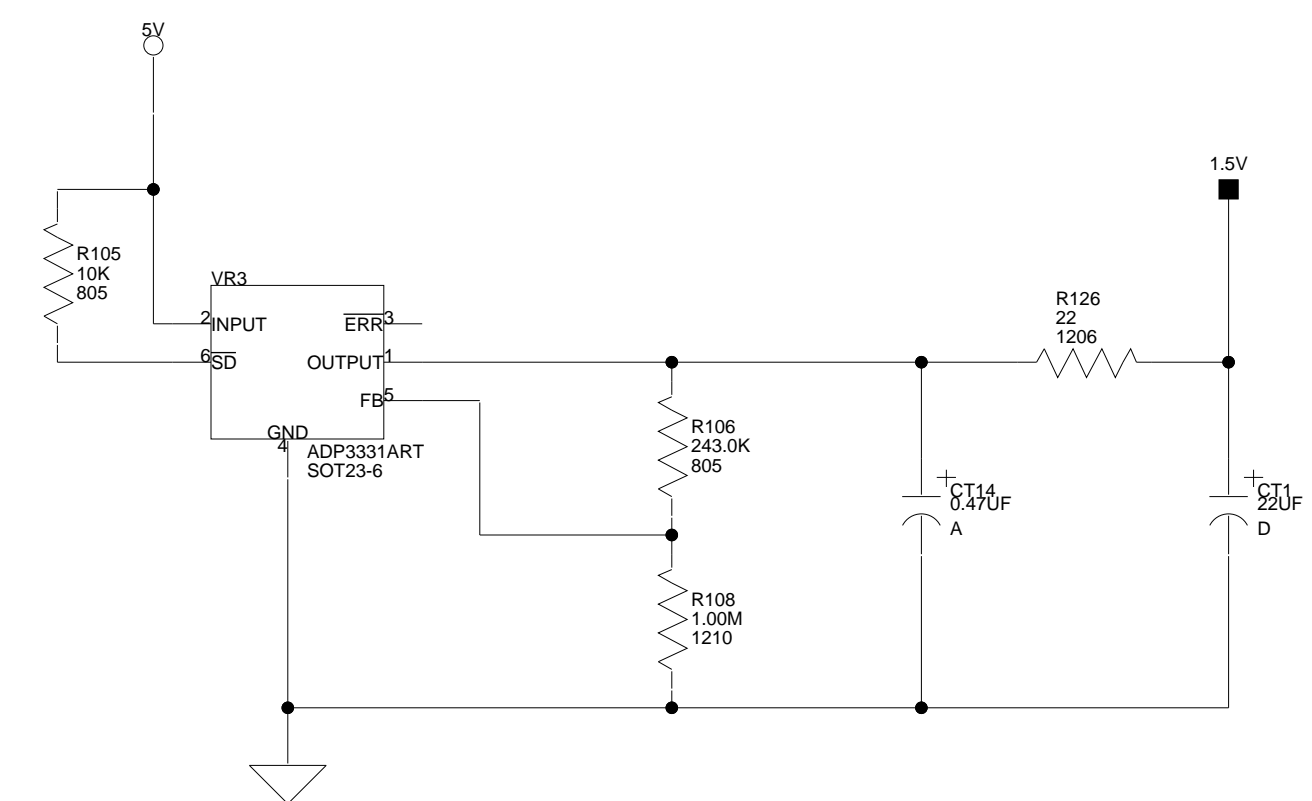
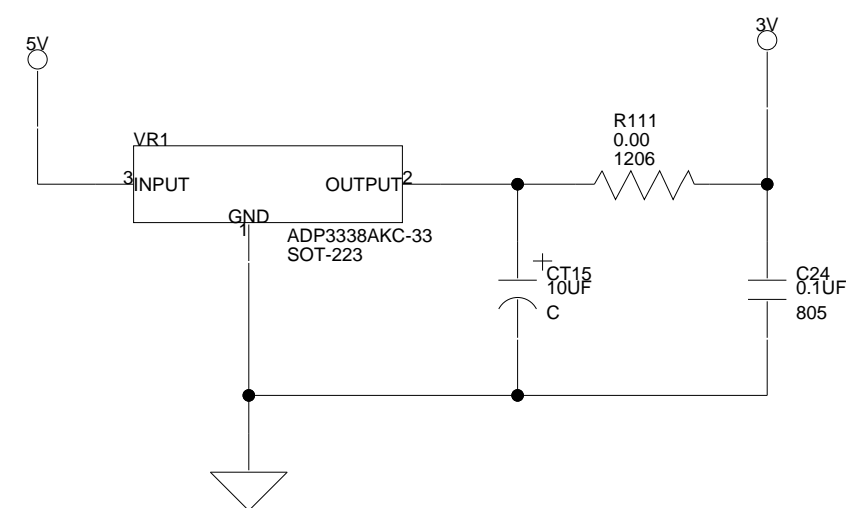
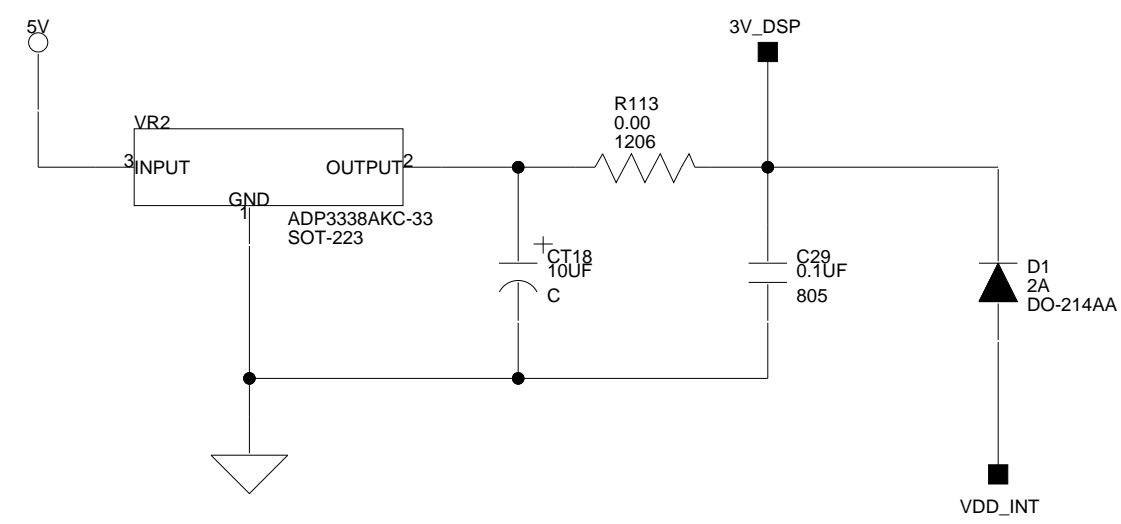
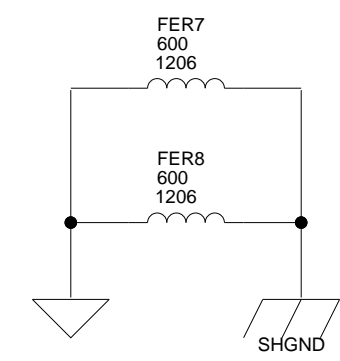
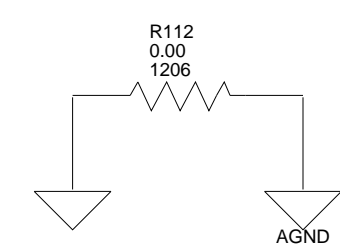
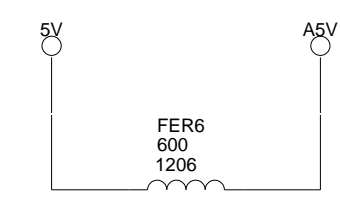
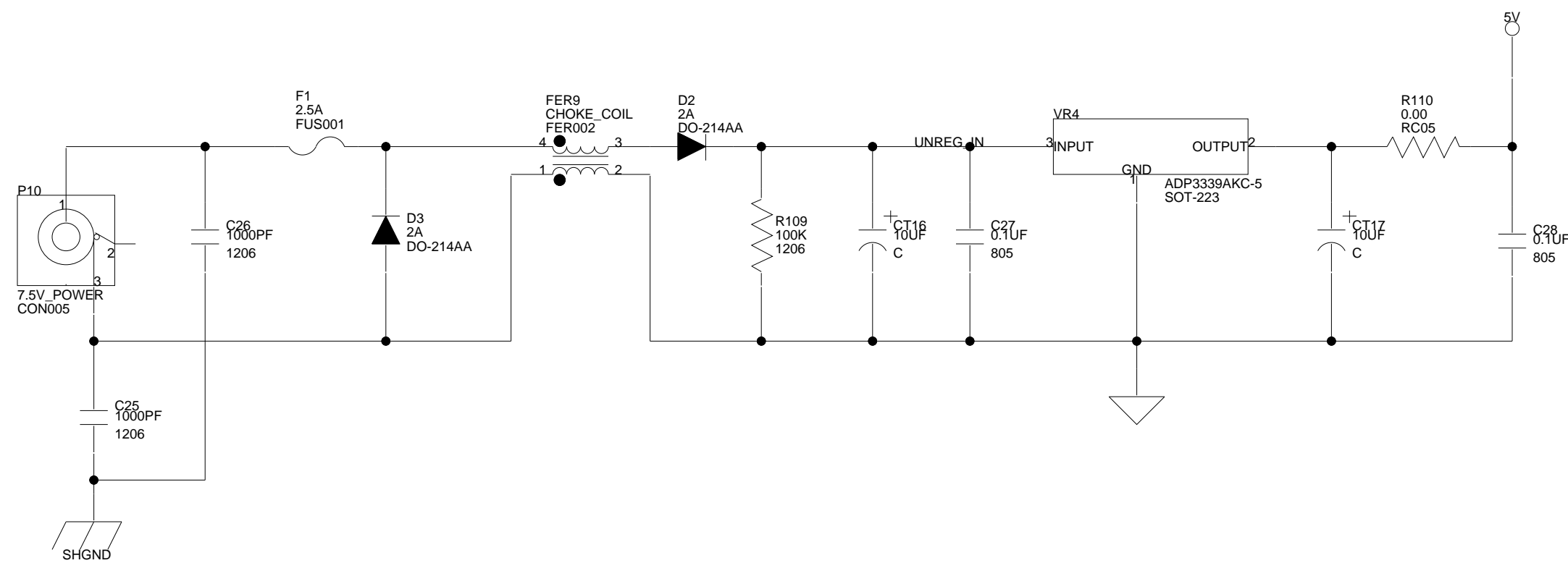

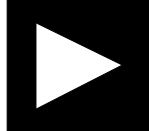
 ANALOG DEVICES 20 Cotton Road Nashua, NH 03063 PH: 1-800-ANALOGD		Title		ADSP-21535 EZ-KIT LITE - POWER 2	
		Size	Board No.	A0162-2000	
Date		5-3-2002_12:31		Sheet 9 of 10	

Approvals	Date
Drawn	5/11/02
Checked	
Engineering	

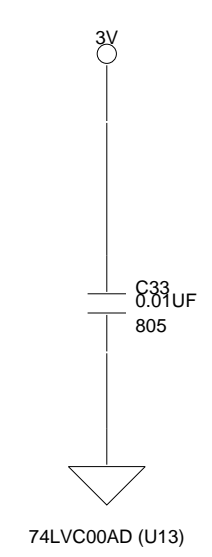
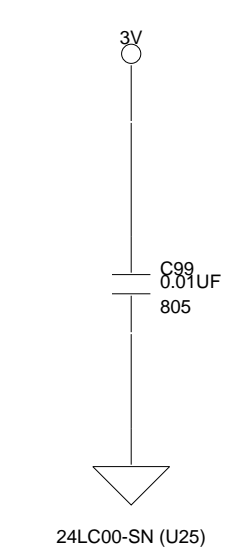
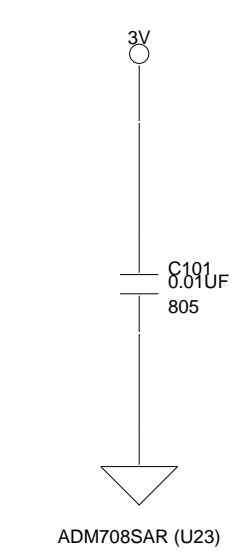
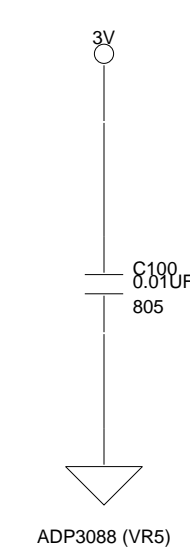
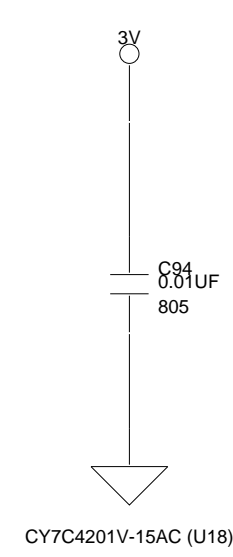
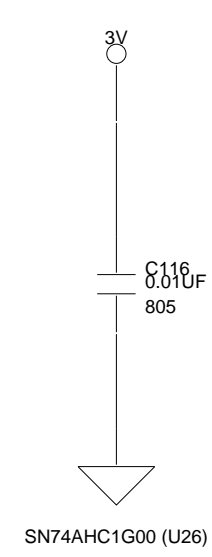
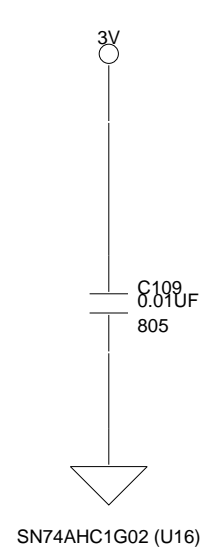
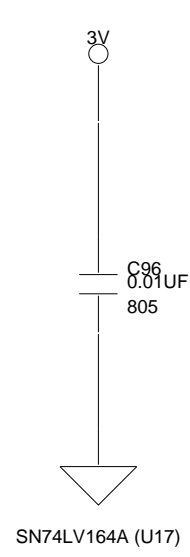
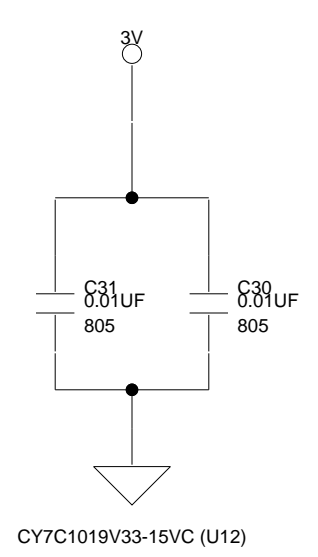
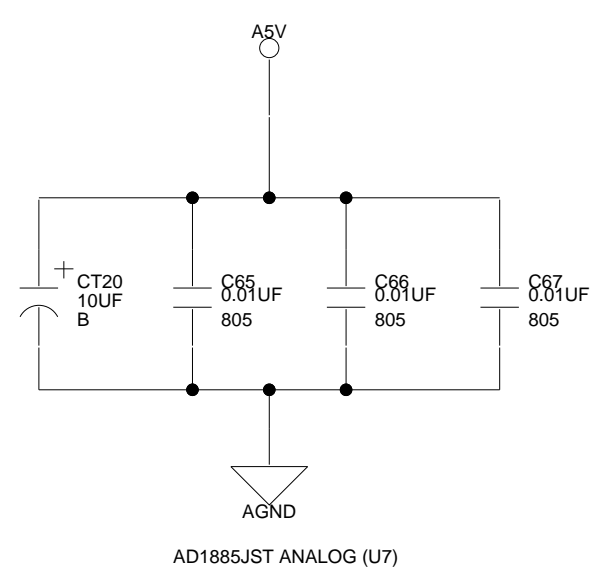
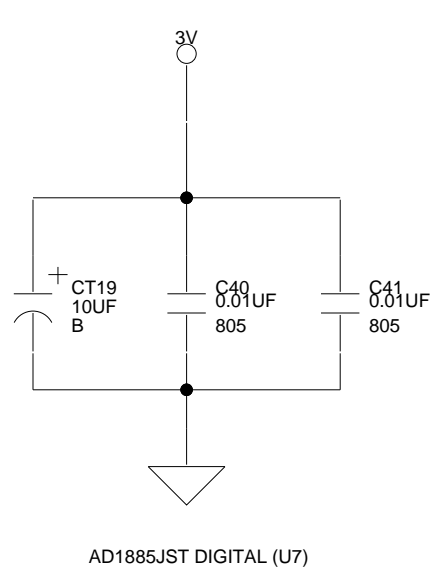
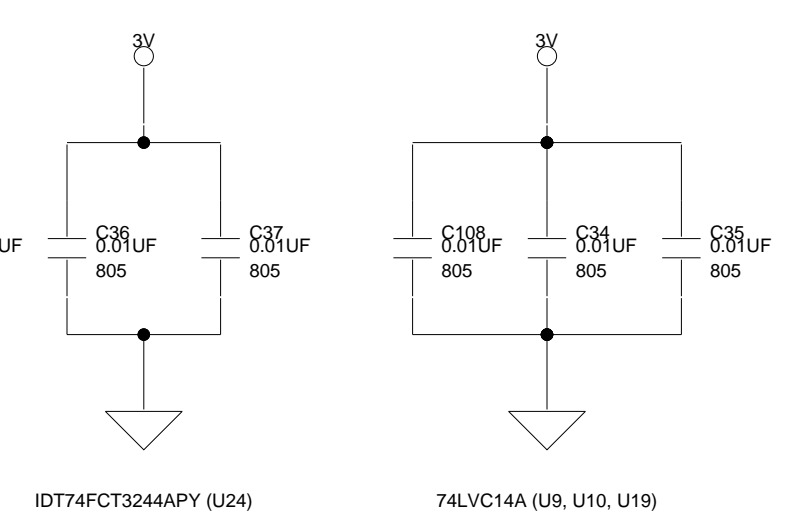
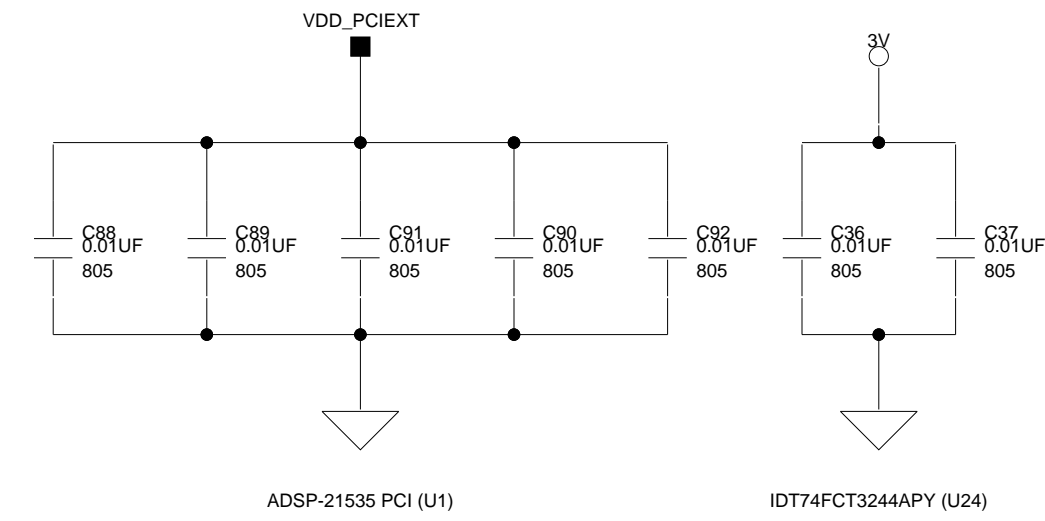
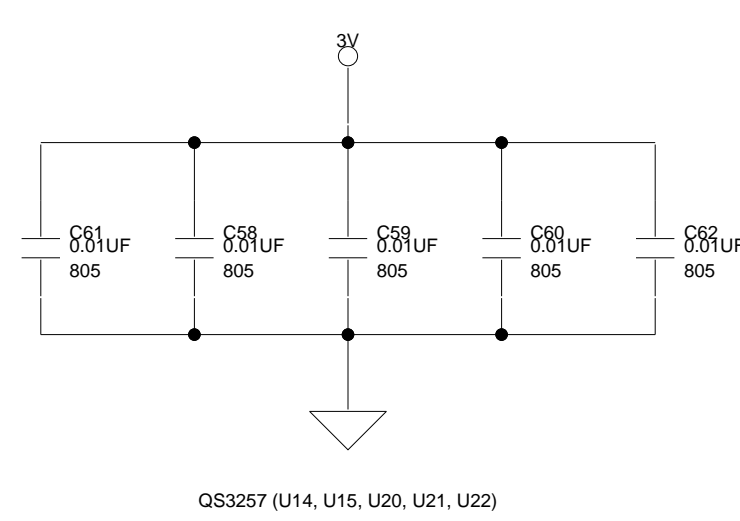
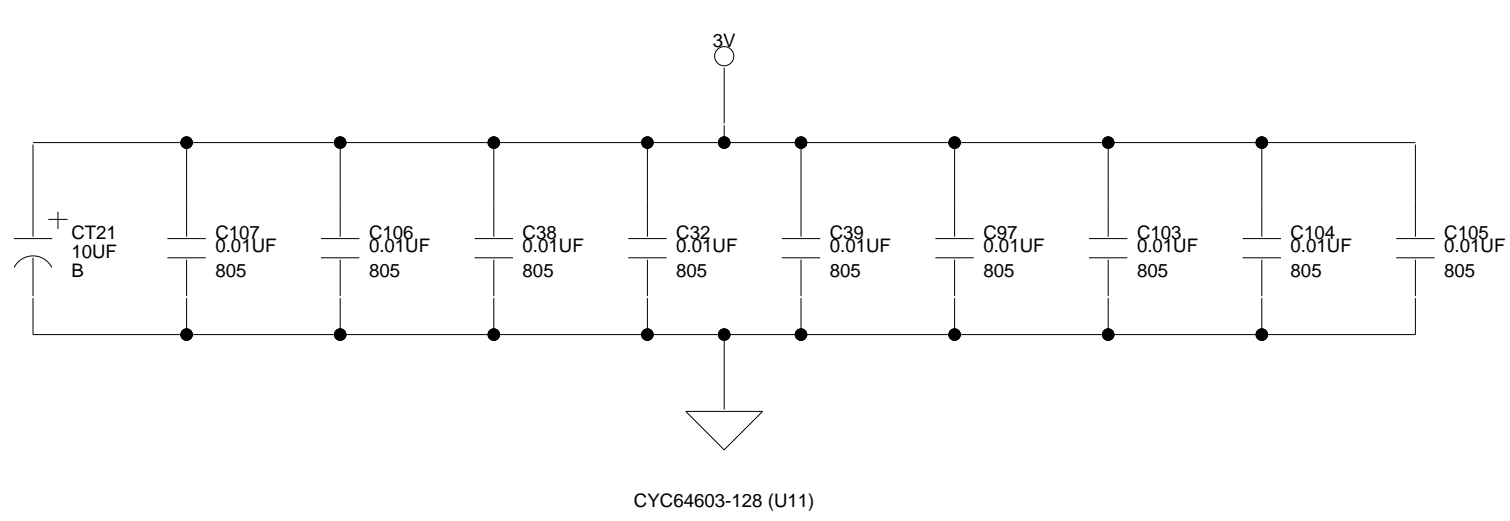
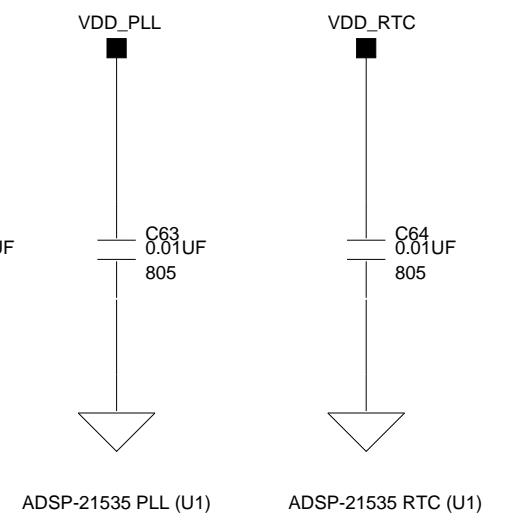
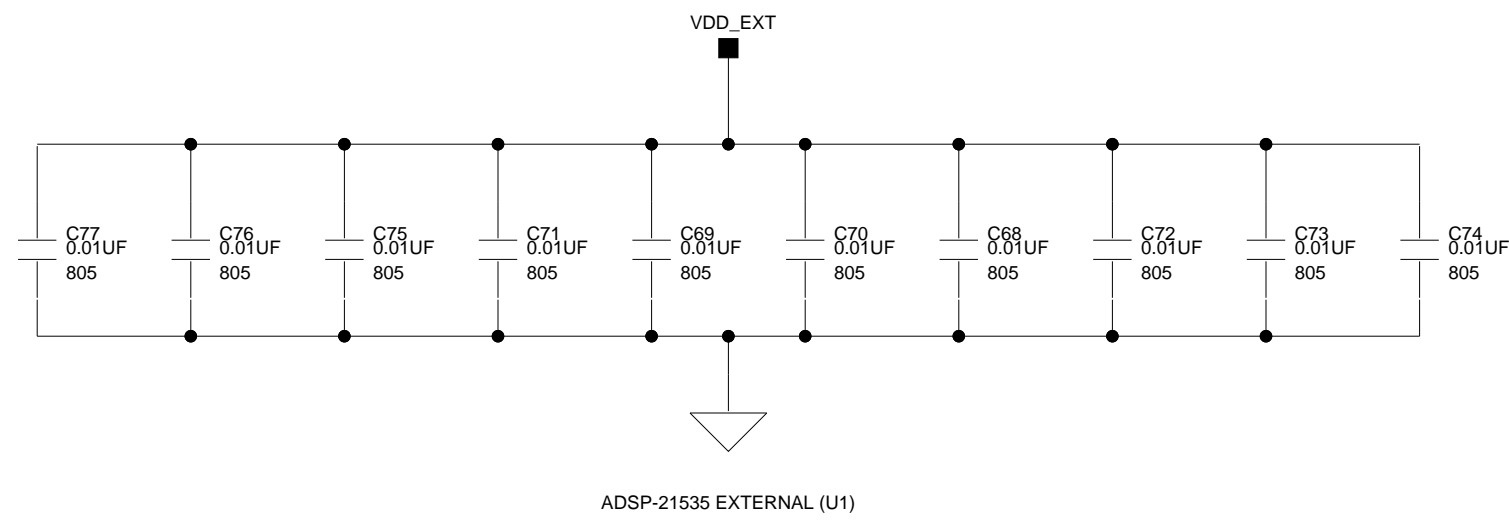
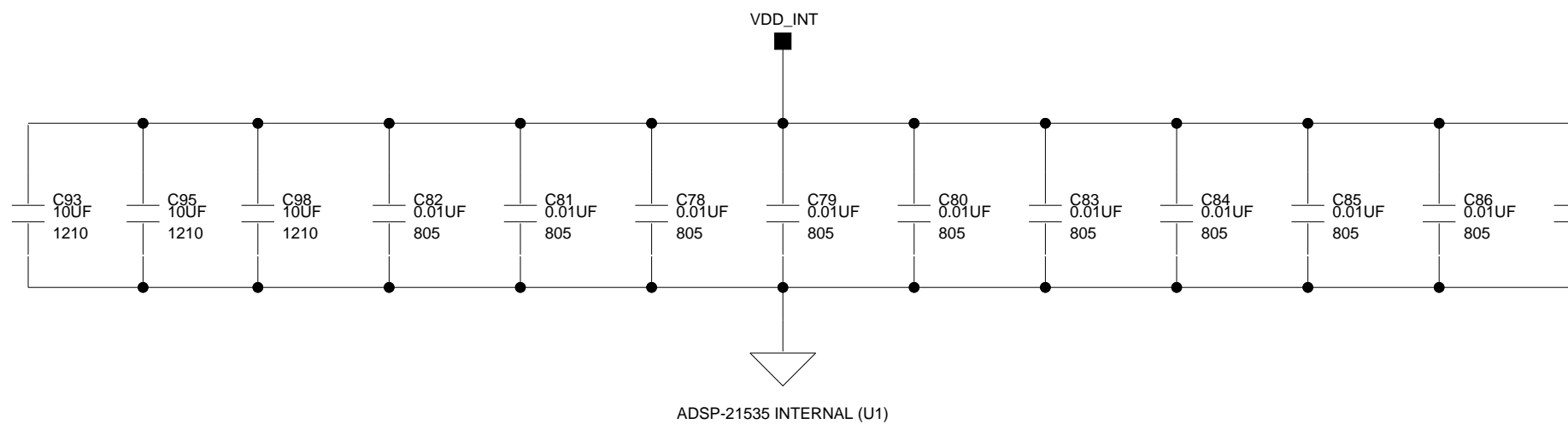
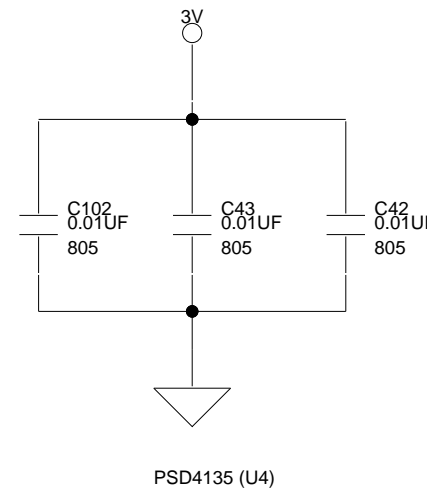
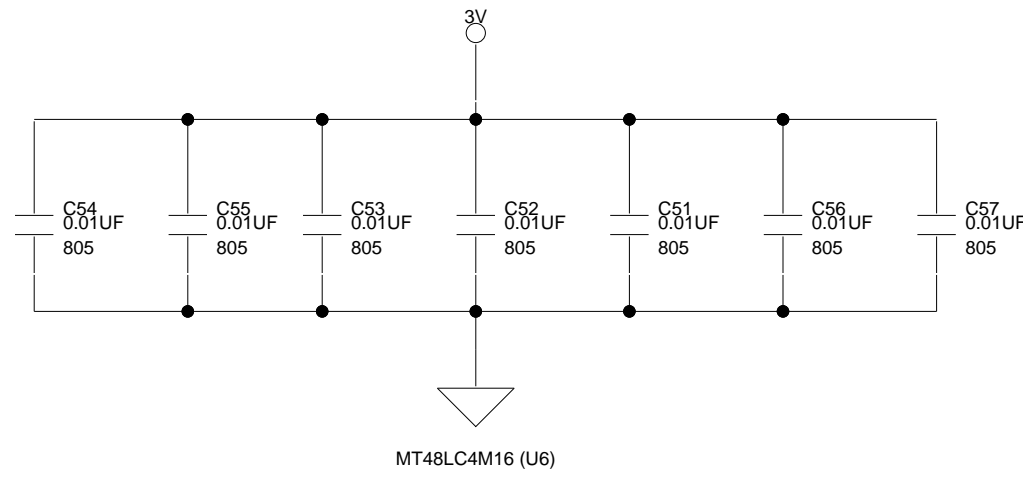
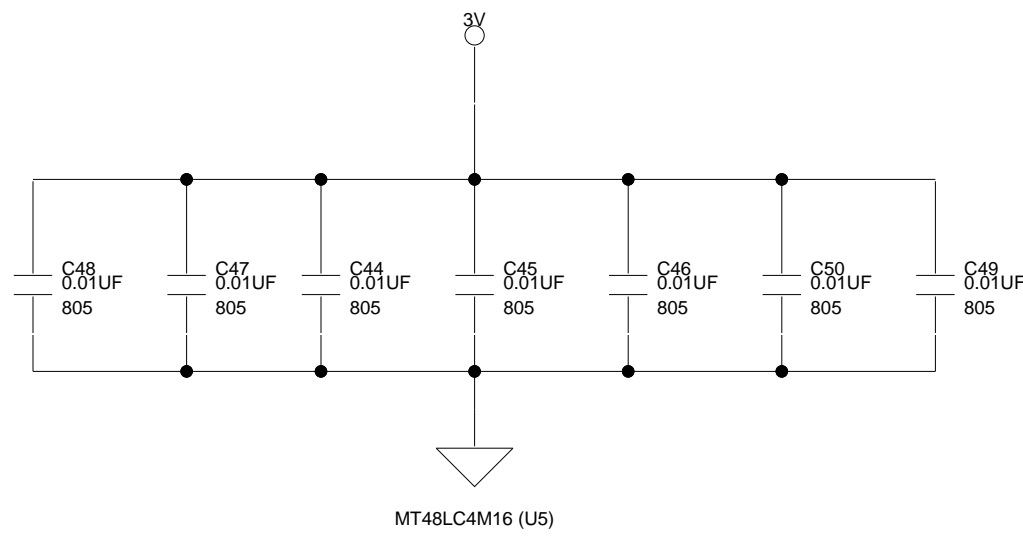

		20 Cotton Road Nashua, NH 03063 PH: 1-800-ANALOGD	
		Title ADSP-21535 EZ-KIT LITE - BYPASS CAPS	
Approvals Drawn Checked Engineering	Date 5/11/02	Size C Board No. A0162-2000	Rev 1.4
Date 5-3-2002_12:31		Sheet 10 of 10	

INDEX

A

architecture..... 4-2
audio..... 4-12

B

boot mode select 4-6

C

connectors 4-11
 P1,P2,P3 4-3, 4-12
 P10 4-14
 P4 3-3, 4-12
 P5 4-3, 4-5, 4-12
 P6 4-3, 4-12
 P7 4-13
 P8 4-13
 P8 4-4
 P9 4-3, 4-14
 power management 3-6
contents 2-1
core voltage..... 4-2
current measurements 4-15
customer support..... 1-3

D

documents 1-4

E

example programs..... 3-6
External Bus Interface Unit 4-3

F

features..... 1-1
flash memory 3-2, 3-3, 4-3, 4-12
Flash Programmer Utility 3-6

H

Help, online..... 1-4

I

installation..... 2-2, 2-9
 verification 2-14
 Windows 2000 USB Driver 2-10
 Windows 98 USB Driver 2-5
interfaces

 audio..... See SPORT0
 expansion See connectors:P1,P2,P3
 JTAG..... See JTAG
IO voltage..... 4-2

J

JTAG..... 4-4, 4-13
jumpers..... 4-5
 default settings 2-4
 JP1 4-3, 4-5, 4-6
 JP2 4-3, 4-6

L

LEDs 3-5, 4-1, 4-8
 LED1 4-9
 LED2 4-9
 LED3 4-9
 LED4 4-9
 LED5 2-14, 2-15, 4-9
 LED6 2-5, 4-9
 LED7 2-5, 4-9
 LED8 2-5, 4-9

M

memory map 3-2

N

NMI..... 4-9

P

PC configuration 2-2
Phase Lock Loop (PLL)..... 4-2, 4-6
power connector..... 4-14
Programmable Flags 3-5, 4-6
 LEDs 4-9
 PF14-PF12 3-6
 push buttons 4-10
push buttons 4-8. *See also* switches

R

Real Time Clock (RTC)..... 4-2
reset 4-9
 board 4-10
 DSP 4-9
restrictions..... 3-2

S

SDRAM	3-2, 3-3
SPORT0	4-3, 4-14
audio codec disable	4-6
switches	4-8
default settings	2-4
SW1	4-6
SW2	4-2, 4-6
SW3	3-5, 4-9
SW4	3-5, 4-10
SW5	3-5, 4-10
SW6	3-5, 4-10

SW7	3-5, 4-10
SW8	4-10

U

USB	4-13
monitor LED	4-9

V

VisualDSP++	
Help	1-4
license	2-3, 3-2
starting	2-15